

Fine Motor Assessment in Upper Extremity Using Custom-Made Electronic Pegboard Test

Abstract

A fine motor test involves the manipulation of smaller objects with fingers, hands, and wrists. This test is an integral part of the evaluation of an upper extremity function. Nine Hole Peg Test (NHPT) is one among such tests which assess the ability to manipulate pegs with the thumb and finger. There is a need to develop a fine motor assessment tool which is reproducible and mimics closely the natural movement of hands. The aim of this work is to develop an electronic pegboard which is easy to administer and efficient in terms of time. Pegboard device is modified and standardized by (1) Adding electronic circuits to custom-made pegboard and programmed using a microcontroller (ATmega2560), (2) Following a specific sequence in placing and picking the pegs from the board, and (3) Using Infrared sensor and robust algorithm to ensure one peg movement at a time. The setup is administered on 15 healthy participants (nine females, six males aged between 21 and 80) and the outcome is compared with the results of traditional NHPT. Predefined sequence in moving the pegs and electronic timer features provide reliable results for repeated measurements and facilitate storing test score in a digital repository. This data could be used as reference data during the follow-up visits. The maximum difference between the measured timing between the present setup and traditional NHPT is about 6.7%. It is important to note that, due to inherent delay (response time) in the traditional NHPT, when compared to present setup the measured timing is always on the higher side. Nondependency on the manual stopwatch to record the time and hands-free of any wearable device are the advantages of the present setup.

Keywords: *Electronic pegboard, fine motor test, infrared sensor, microcontroller, Nine Hole Peg Test*

Submitted: 16-Aug-2020

Revised: 16-Aug-2020

Accepted: 11-Mar-2021

Published: 28-Dec-2021

Introduction

Hand functions are synchronized with daily activities which are centrally controlled by the brain. Hand assessment is a process of examination by which the quality of a persons' hand function is quantified and judged. This assessment helps in defining the persons' problem and is the foundation for selecting and directing treatment.^[1] Standardized hand function tests mainly consist of three components: (a) Arm and hand function tests, (b) Dexterity and fine motor tests, and (c) hand strength test. In literature, there exist multiple fine motor tests, namely Nine-Hole Peg Test (NHPT),^[2] Purdue Pegboard Test,^[3] Moberg Pick-up Test,^[4] Minnesota Rate of Manipulation Test,^[5] Box and Block Test,^[6] and Coin Rotation

Test^[7] are some of the test batteries to examine fine motor function. These tests are all time-based test for examining the fine motor which is defined as the skill in performing tasks using hands. NHPT is a standard, reliable, and well-established test battery setup used in the objective measure of hand function. Among fine motor test devices, NHPT is very easy to administer, takes <15 min and is considered to be reliable,^[8] valid,^[9,10] and sensitive to change.^[10,11] There are pegboard tests with eight pegs or 16 pegs having different dimensions but NHPT is the most widely accepted way of monitoring arm and hand function in clinical trials.^[12] Mathiowetz *et al.* have developed normative data and detailed test instructions for NHPT with healthy adult population and have validated the test results.^[13] NHPT evaluates fine manual dexterity with a patient population such as multiple sclerosis (MS), Parkinson

This is an open access journal, and articles are distributed under the terms of the Creative Commons Attribution-NonCommercial-ShareAlike 4.0 License, which allows others to remix, tweak, and build upon the work non-commercially, as long as appropriate credit is given and the new creations are licensed under the identical terms.

For reprints contact: WKHLRPMedknow_reprints@wolterskluwer.com

K. Aneesha Acharya¹, Somashekara Bhat², M. Kanthi², Bhamini Krishna Rao³

Departments of ¹Instrumentation and Control Engineering and ²Electronics and Communication Engineering, Manipal Institute of Technology, Manipal Academy of Higher Education, ³Department of Physiotherapy, Manipal College of Health Professions, Manipal Academy of Higher Education, Manipal, Karnataka, India

Address for correspondence:
Dr. Somashekara Bhat,
Department of Electronics and Communication Engineering,
Manipal Institute of Technology,
Manipal Academy of Higher Education, Manipal, Karnataka, India.
E-mail: soma.bhat@manipal.edu

Access this article online

Website: www.jmssjournal.net

DOI: 10.4103/jmss.JMSS_58_20

Quick Response Code:



How to cite this article: Acharya KA, Bhat S, Kanthi M, Rao BK. Fine motor assessment in upper extremity using custom-made electronic pegboard test. *J Med Sign Sens* 2022;12:76-83.

disease (PD), stroke, and brain injury. Wade *et al.* have tested hand dexterity using nine-hole as well as ten-hole peg test and found good assessment is possible with NHPT.^[14] Wang *et al.* recommend including NHPT in the motor battery of the National Institutes of Health Toolbox.^[15]

The traditional NHPT introduced by Keller is considered as a gold standard for fine motor function.^[12] The test kit consists of a plastic board, nine pegs (dimension: 7 mm diameter, 32 mm length) and a stopwatch as shown in Figure 1. To perform the test, the participant is positioned comfortably in a chair and hands are resting on a table, adjacent to either side of the pegboard. The participant is asked to hold pegs from peg holder and place in a pegboard. Nine pegs are placed into the holes of a pegboard one at a time in any pattern. Instruction to the test procedure is as follows: "Pick up the pegs one at a time, using your dominant hand and put them into the holes in any order until all the holes are filled. Then, pick-up the pegs one at a time and return them to the peg holder. Stabilize the pegboard using the hand which is not in use. See how fast you can put all the pegs in and take them out again. Are you ready? Go!".^[6] Total time to complete the task is timed using a manual stopwatch. In case the person is unable to complete the test within 300s, a total number of pegs placed within this time limit are counted. The activity is repeated for both dominant and nondominant hand separately.

Jobbágy *et al.* have developed a sophisticated NHPT with LEDs.^[16] The movement pattern is guided with LED's which are present adjacent to each pegboard holes. The developed device calculates the time taken to complete the test automatically. There is a possibility that the participant can hold multiple pegs to speed up the process. This test kit would not consider this possibility. This kind of performance from the participant violates the test procedure and gives the wrong test score. In the present research work, an IR sensor and a robust algorithm is used such that timing is initiated only if the participant follows the sequence and subsequent peg movement will be recognized only when there is a hand movement toward peg holder to pick the peg. This arrangement makes user to compulsorily pick pegs one at a time and place it in the predefined order. This makes the scoring method hassle-free and it is easy to examine improvement during subsequent visit based on the test score.

Johansson and Hager^[17] have developed standardized NHPT setup which consists of two pegboards. Nine pegs are moved one at a time from one board to another as per the standard instructions. Kinematic assessment is performed for 30 participants with the help of 8 cameras and 9 passive reflective markers. In this NHPT, a person must hold one peg at a time from one pegboard to another pegboard during the placement and pick-up of pegs rather than using a peg holder as in the traditional pegboard test.

Many of the existing electronic pegboard tests use a motion suite which consists of Kinect sensor, wearable sensors, or multiple sensors on hand glove, etc., For example, Martin-Martin and Cuesta-Vargas^[18] have used kinematic and electromyographic signals from each finger and palm using accelerometer and electromyography. A calibration procedure is required before the actual test performance to avoid the sensor positional error in case of sensors placed inside the hand glove. This calibration steps and wearable sensors work well in the laboratory set-up, but it is challenging to make a portable and easy to use the product in a clinical setup. Video observation of the experiment is another option to examine the kinematic of hand movement. This has the disadvantage that the recordings must be assessed by multiple experts, making the method potentially subjective and time-consuming.^[19] Nowadays, virtual environment is making a buzz in a variety of video gaming consoles which is also used in the pegboard test. These virtual pegboard techniques encourage the participant to perform hand-related gestures. However, precise movement with real objects is left untouched. Activity initiation and completion with precision are entirely different aspects which are not reflected in the custom game-based active devices. Furthermore, continuous monitoring of virtual display to keep track of the pegboard setup restricts the actual hand usage such as grasping and dexterity.^[20] A clinician has a limited amount of time due to the large patient population and effective one to one intervention may not be feasible always. Thus, there is a need to develop portable, cost-effective, and easy to use pegboard which is easy to administer and time efficient.

Methods

The hardware design and test battery were developed with the input from a physiotherapy expert working for Manipal College of Health Professions, Manipal. Ethics Committee of Kasturba Hospital, Manipal has approved the use of electronic pegboard device on healthy participants (Registration No. ECR/146/Inst/KA/2013).

Block diagram of the board along with all the associated hardware is shown in Figure 2. Pegboard is 3-D printed using Acrylonitrile Butadiene Styrene material. Enough holes are made underneath the pegboard to insert LDR and LEDs. Present work utilizes an ATmega2560 microcontroller, LDR, LED, 3D model of the pegboard with required circuitry and LCD to show the peg count and test execution time. The whole setup is shown in Figure 3. Placement of the peg inside the hole is detected when the peg blocks the light between the LED and LDR. The status is restored when the peg is taken out from the hole. The absence and presence of light is used to detect the placement and removal of the peg from the hole. The total development cost of the setup is about 25USD, whereas the traditional pegboard available in market costs around 189.92USD.^[21]

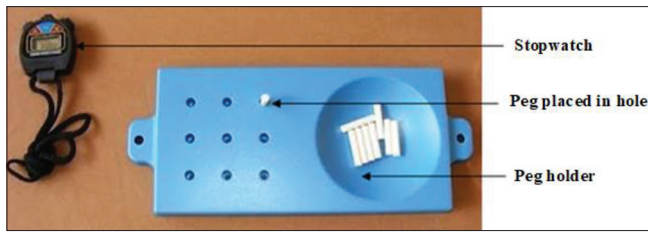

Figure 1: Traditional Nine Hole Peg Test (NHPT) set-up with the stopwatch

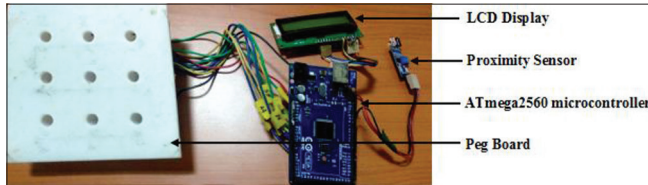

Figure 3: Working model of sensor-based pegboard test up

The test procedure requires a chair for the participant to sit and a table to place the device. Hand assessment procedure involves, making the participant to sit with the firm back on a chair without armrest. A table with the height fixed to waist level is placed in front of the chair. Participants' trunk during the performance of the test must always be in contact with the back of the chair. The test setup is kept on the table and the participant is asked to place nine pegs in a pegboard in a specified pattern [Figure 4]. Four trials are performed (two trials for each hand) during single session with 15s interval between each repetition. Test is conducted for both hands in case of generating normative data for healthy adults and only for impaired hand in case of patient population. Using a specific pattern in placement and picking up the pegs will avoid participant placing the pegs in random positions. This helps the therapist in providing reliable results for repeated measures. Another benefit of following a specific pattern is, during follow-up assessments, by making the participant to repeat the same patterns, it becomes easier for the physiotherapist to assess the improvement.

Based on the purpose of the test, different test procedure is followed. Two such scenarios are highlighted here.

Scenario 1: For an employment purpose, it may be required to know the dominant hand of the employee or to prescreen employees for jobs that require coordination with fingers and fine motor function. In such a scenario, following test procedure is followed.

1. Wait for the instruction: "Pick up the pegs one at a time from the peg holder using dominant hand and put them into the holes in a given order until all the holes are filled. Pick-up the pegs one at a time and return them to the peg holder in the reverse order. See how fast you can put all the pegs in and take them out again. Are you ready? Go!"
2. Place the pegs (one at a time) from the peg holder into the pegboard holes using the dominant hand in the specified order

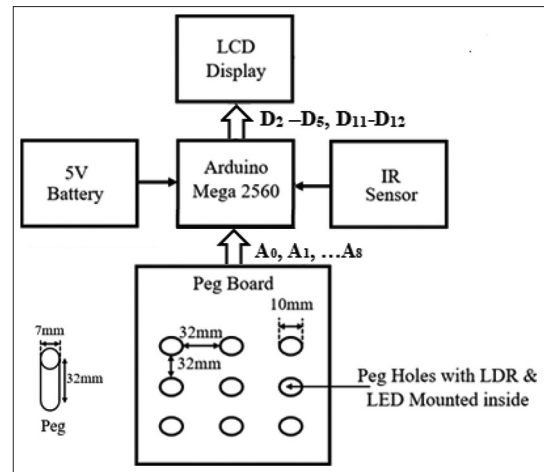

Figure 2: Block diagram representation of the pegboard test set-up

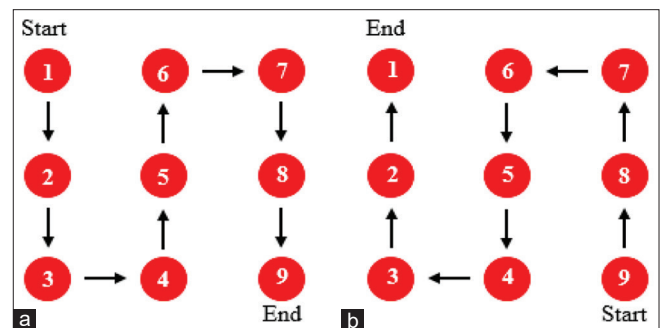

Figure 4: Sequence for (a) Placement (b) Pick-up of pegs

3. Continue this process till all the pegs are placed
4. Place the pegs back into the peg holder one at a time by taking out the pegs from the pegboard in the reverse order
5. Repeat the process with the nondominant hand.

Scenario 2: To plan a therapeutic session for a person with impairment in one hand. In such a scenario, above steps are followed except that the process is carried out only with impaired hand.

At the end of the test process, time to complete the task is calculated automatically. Variation in the resistance of the LDR is used to start the timer, which provides the total time taken to perform the test. In case the person is unable to complete the task within the specified time, the number of pegs placed within that time is counted, and the number of pegs placed called the "peg count" is displayed.

Technical aspects of the device

The circuit involving LED and LDR is shown in Figure 5. The LED and LDR are oriented such that the light from the LED always falls on the LDR. Furthermore, the arrangement is such that ambient lighting condition does not affect LDR output. The LDR and a 220kΩ resistor forms a potential divider and the drop across 220kΩ resistor is connected to one of the analog input pins (A_8 to A_0) of

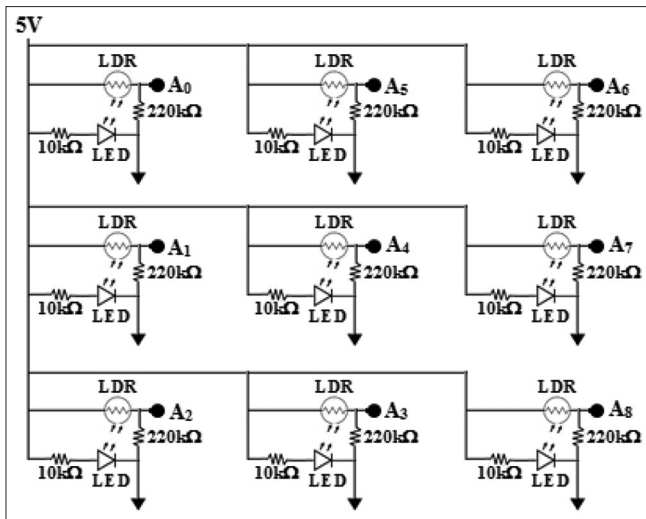

Figure 5: Arrangement of LDR-LED pair and associated connections inside each peg hole

microcontroller [Figure 5]. Whenever enough LED light falls on the LDR, it exhibits low resistance. The process of placing the peg in the hole blocks the light falling on LDR and the respective LDR resistance rises. Due to this, drop across connected 220kΩ resistor drops. If this drop is at A₀ input, then the timer starts counting the activity time. If the drop is at A₈ input, then the timer continues to count; however, in the backend, total time taken for placing the pegs is calculated. As the pegs are removed one by one, at the end when A₀ signal level is restored, it is the end of the activity. The timer stops counting and the total activity time are displayed. Along with the activity time, peg count is also displayed, which corresponds to number of hand movements. If the activity is performed as per the guideline, there should be 18 hand movements. To keep track of this, a Proximity IR sensor (KY-033) with internal circuitry as shown in Figure 6 is used. As and when hand is moved to pick the peg, IR radiation emitted from LED is blocked by the hand, which is detected by the photodiode. The photodiode output is compared with a reference signal using LM393, the output of which becomes the digital input line (D₆) of Arduino. When the Arduino receives any of the signals (A₈ to A₀) and the signal D₆, the activities that are performed by the participant is recorded. The working of the setup is explained in the flowchart [Figures 7 and 8].

Once all the pegs are placed, and pick-up activity completes, the hardware displays the total activity time and total hand movements. To avoid unintentional delay, an upper limit on time to complete the activity has been fixed at 300s.^[12] If the activity is not completed within this time, the timer will display “Time out” and will display the number of hand movements completed successfully till that instant. If the proper sequence is not followed in placing or removing the pegs, a “Time out” message is displayed. Table 1 lists all these possible scenarios and the respective display message.

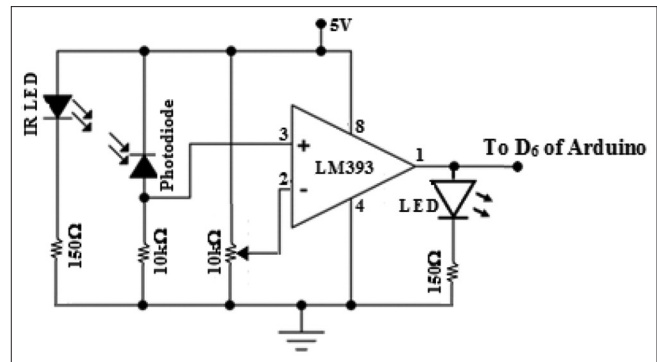

Figure 6: Internal circuit diagram of IR sensor

Results

Fifteen healthy participants have participated during the pegboard test. A healthy population is considered to verify the functionality of electronic pegboard (present setup), and the outcome is compared with the results of test conducted on same population using traditional NHPT. As per age, participants are divided into three categories: 21–35, 36–55, and 61–80 years. Table 2 shows the time taken in seconds for the tests conducted by traditional NHPT and present setup. The standard deviation of the traditional and electronic method in all the three age groups are shown in Figure 9. From the Table 2, it is inferred that results of the electronic pegboard test are comparable to NHPT data which is a gold standard.

Average value of the total time [Table 2] is considered for the comparison between traditional NHPT and electronic pegboard test setup. The test is conducted using traditional NHPT and electronic pegboard for ensuring the feasibility of developed device usage in real time. The infrared sensor used in this electronic pegboard and robust algorithm ensures one peg movement at a time. Only if the total number of hand movements are 18 (which is equal to the total number of pegs placed and removed from the board), total execution time is displayed. The total time can be calculated without using the stopwatch and can be saved automatically for future use.

Implication of the results for physiotherapy practice

As an outcome of the present work, following inferences are drawn for physiotherapy practice.

1. Repeated trials of pegboard test in the normal adult population significantly improve test performance in as few as four trials
2. In a traditional NHPT, time calculation starts after the “Go” instruction from clinician. In the present setup, placement of peg at first hole position triggers the timer. This automation increases the reliability of test results
3. In a traditional pegboard test, during the stopwatch usage, delay exists from the clinician end, which is commonly known as “response time.” Due to this, an activity timed using multiple clinicians would result in different timing

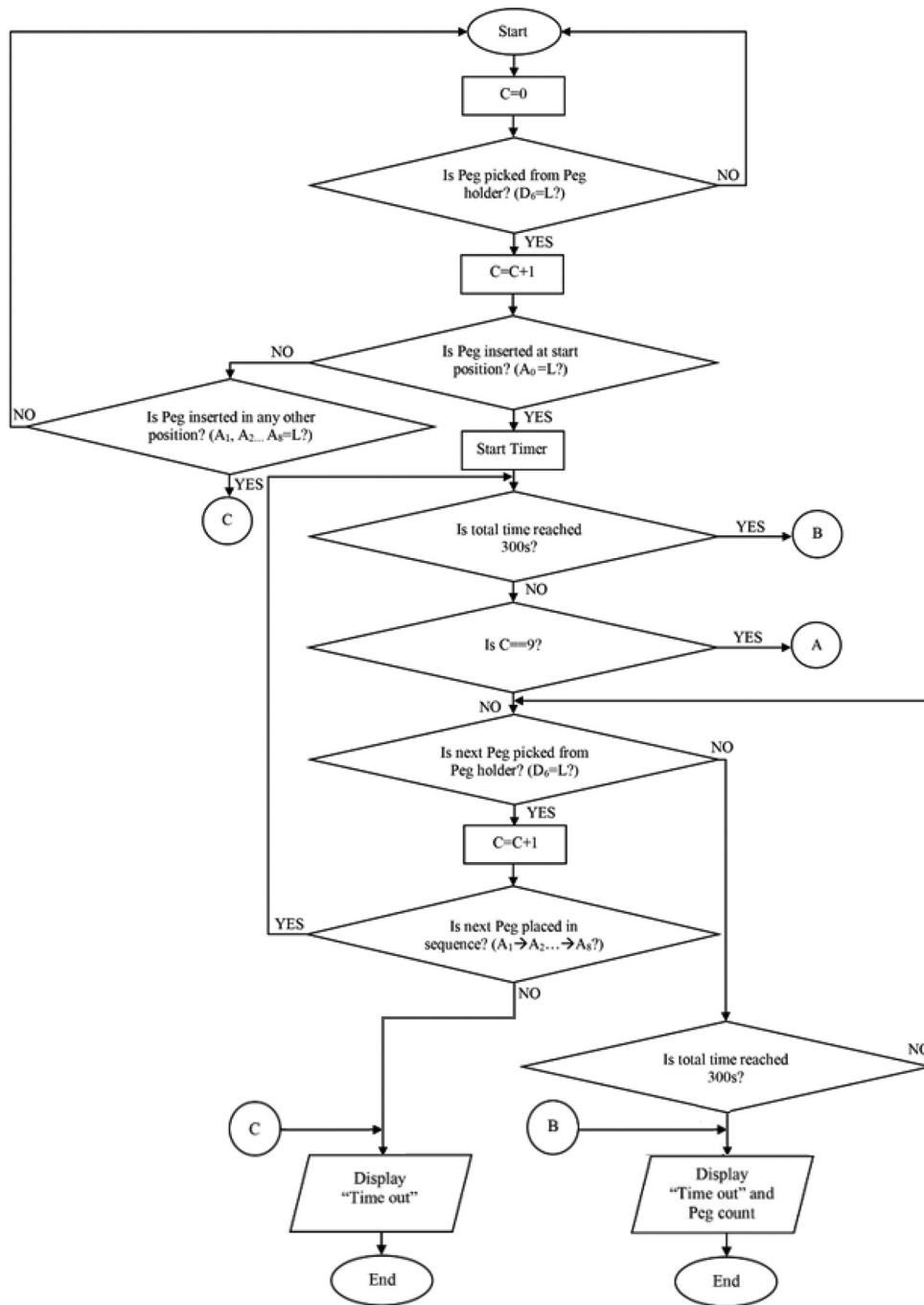

Figure 7: Flowchart explaining programming of the setup. Note: Figure continues in next page

Table 1: Possible scenarios during peg placement

Scenario	Display
All the pegs are placed and removed from the board in proper sequence and activity is completed within the time limit	Activity time
Pegs are placed and removed from the board in proper sequence, but activity is not completed within the time limit	“Time out” and peg count
Proper sequence is followed while placing but not followed while removing the pegs	“Time out” and peg count
Proper sequence is not followed in either while placing or removing the pegs	“Time out”
Hand movement is detected but pegs are not placed on the pegboard within the time limit	“Time out”

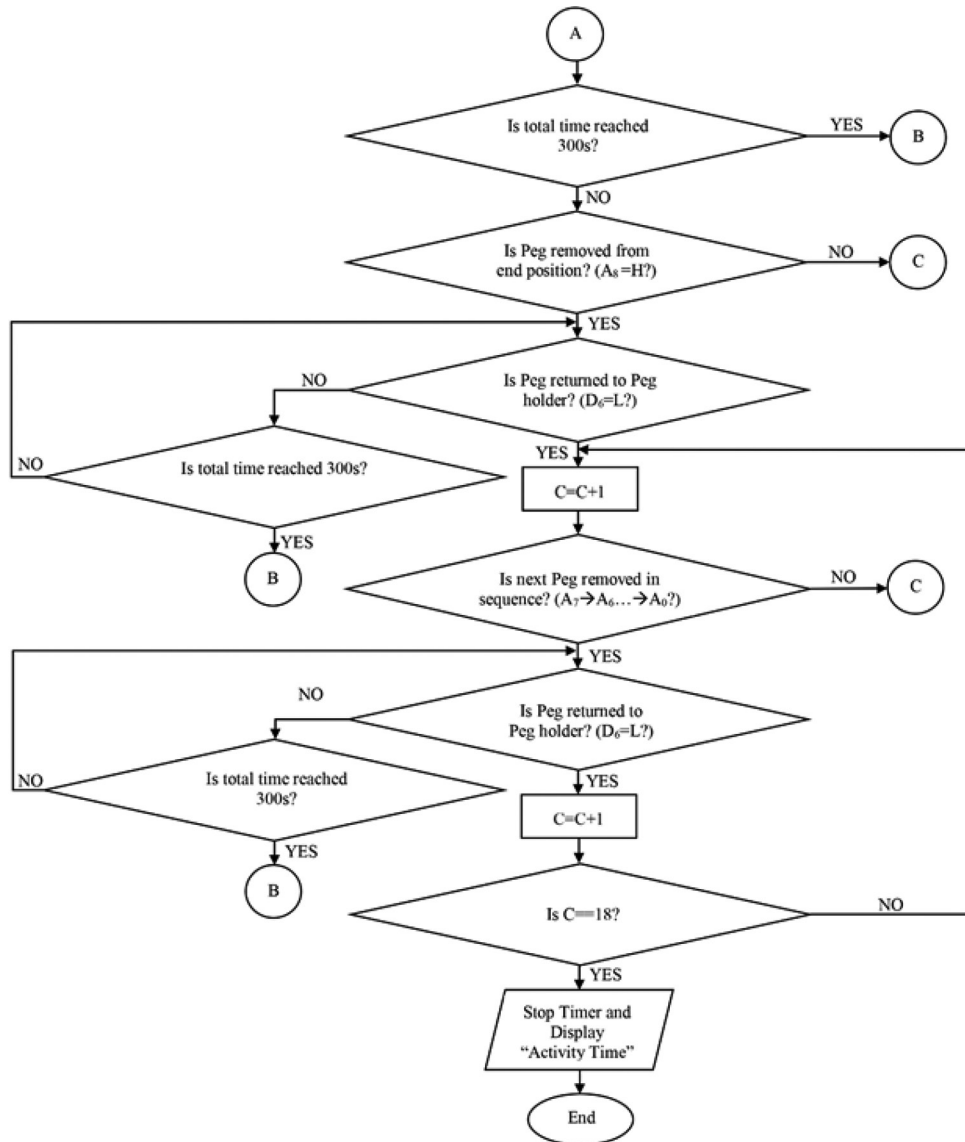

Figure 8: Flowchart explaining the programming of the setup. (Note: Figure 8 is continuation of Figure 7)

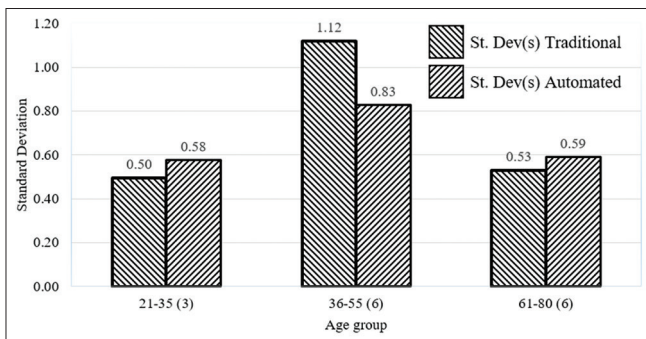

Figure 9: Standard deviation between the traditional and electronic pegboard test results

values. This drawback is easily overcome by introducing the electronic timer in the present setup

- While placing and removing the pegs from the board, following a specific pattern in the present setup improves the test-retest reliability.

Table 2: Pegboard test result for healthy participants

Tested participants	Traditional pegboard test		Electronic pegboard test	
	Average (s)	SD (s)	Average (s)	SD (s)
Age group				
21-35 (3 persons)	23.03	0.50	21.48	0.58
36-55 (6 persons)	23.49	0.83	22.11	1.12
61-80 (6 persons)	24.60	0.53	23.70	0.59

SD: Standard deviation

Discussion and Conclusion

Pegboard tests are an amazing system utilized to assess fine motor skills. It has been proved to be a very useful tool for improving the motor skills and efficiency of the people in the clinical set-up. NHPT can discriminate the improvement in the particular patient population such as MS, PD,^[22,23] and Stroke^[24] serves as easily administered

upper extremity assessment tool. A general observation from the physician is that whenever hands are tagged by some wired devices, the patient tends to be more conscious, due to which outcome measures may not reflect the real scenario. In the present work, no wearable devices are placed on participant thus facilitating free movement of the hand. The main objective of the work was to develop an “electronic pegboard” which not only tells about timing information of the activity but also about the record of the peg’s movement. The infrared sensor used in this test will ensure the accountability of the hand movement. Thus, there is no scope to place multiple pegs at a time which is added advantage over traditional NHPT. In traditional pegboard test, while participant is performing the test, clinician need to concentrate on stopwatch. There could be a delay in starting and stopping the timer, which is commonly known as “response time”. Furthermore, when multiple clinicians record the timing for the same event, there is a variation in the time reported by them. The variation is as much as 7 s. Even though it may not look significant, as a human instinct, when the measurement is erroneous, patient may start losing the faith in the treatment he is undergoing, which may slowdown the recovery process. In this research work, the electronic model is made to overcome the manual errors and thereby making it a more reliable and accurate system for improving patient’s hand-eye coordination and motor skills. In our setup, as there is a specific pattern to be followed, by asking the patient to repeat the pattern during revisit, it becomes easy to assess the improvement during the successive visits, thus it improves the test-retest reliability. Making the patient to follow the specific pattern could also be used in cognitive assessment. The present setup is simple, light weight, portable easy to use, and test procedure is validated with the standard NHPT.

In the hospital environment, performing a one-to-one assessment is a big challenge and asks for valuable time of clinician. During one of our visits to the physiotherapy department of the hospital, it was full of patients waiting for their turn for the therapy. Clinicians were fully occupied and were handling the cases sequentially as most of the associated measurements were manual which required one-to-one intervention. This was a big challenge for the therapist. Furthermore, improper way of doing a single sub-task may result in a repetition of the whole test, and hence, it is an additional workload on clinician. In the present setup, due to incorporation of automation, clinician need not hold the stopwatch during the execution of test. Thus, it asks for minimum intervention from clinician. The auto time calculation makes the system more reliable and fool proof. At present, the setup is tested with a small sample size. Future work is to test with large population along with additional sensors integrated, (such as inertial sensor and camera) for kinematic assessment of fine motor function.

Financial support and sponsorship

None.

Conflicts of interest

There are no conflicts of interest.

References

1. Bear-Lehman J, Abreu BC. Evaluating the hand: Issues in reliability and validity. *Phys Ther* 1989;69:1025-33.
2. Kellor M, Frost J, Silberberg N, Iversen I, Cummings R. Hand strength and dexterity. *Am J Occup Ther* 1971;25:77-83.
3. Desrosiers J, Hébert R, Bravo G, Dutil E. The Purdue Pegboard Test: normative data for people aged 60 and over. *Disabil Rehabil* 1995;17:217-24.
4. Moberg E. Objective methods for determining the functional value of sensibility in the hand. *J Bone Joint Surg Br* 1958;40-B: 454-76.
5. Drussell RD. Relationship of Minnesota Rate of Manipulation Test with the industrial work performance of the adult cerebral palsied. *Am J Occup Ther* 1959;13:93-6 passim.
6. Mathiowetz V, Volland G, Kashman N, Weber K. Adult norms for the Box and Block Test of manual dexterity. *Am J Occup Ther* 1985;39:386-91.
7. Mendoza JE, Apostolos GT, Humphreys JD, Hanna-Pladdy B, O’Byrant SE. Coin rotation task (CRT): A new test of motor dexterity. *Arch Clin Neuropsychol* 2009;24:287-92.
8. Chen HM, Chen CC, Hsueh IP, Huang SL, Hsieh CL. Test-retest reproducibility and smallest real difference of 5 hand function tests in patients with stroke. *Neurorehabil Neural Repair* 2009;23:435-40.
9. Parker VM, Wade DT, Langton Hewer R. Loss of arm function after stroke: measurement, frequency, and recovery. *Int Rehabil Med* 1986;8:69-73.
10. Beebe JA, Lang CE. Relationships and responsiveness of six upper extremity function tests during the first six months of recovery after stroke. *J Neurol Phys Ther* 2009;33:96-103.
11. Heller A, Wade DT, Wood VA, Sunderland A, Hewer RL, Ward E. Arm function after stroke: measurement and recovery over the first three months. *J Neurol Neurosurg Psychiatry* 1987;50:714-9.
12. Feys P, Lamers I, Francis G, Benedict R, Phillips G, LaRocca N, *et al.* The Nine-Hole Peg Test as a manual dexterity performance measure for multiple sclerosis. *Mult Scler* 2017;23:711-20.
13. Mathiowetz V, Weber K, Kashman N, Volland G. Adult norms for the nine Hole Peg Test of finger dexterity. *Occup Ther J Res* 1985;5:24-38.
14. Wade DT. Measuring arm impairment and disability after stroke. *Int Disabil Stud* 1989;11:89-92.
15. Wang YC, Magasi SR, Bohannon RW, Reuben DB, McCreath HE, Bubela DJ, *et al.* Assessing dexterity function: a comparison of two alternatives for the NIH Toolbox. *J Hand Ther* 2011;24:313-20.
16. Jobbágy Á, Marik AR, Fazekas G. Quantification of the upper extremity motor functions of stroke patients using a smart Nine-Hole Peg tester. *J Healthc Eng* 2018;2018:7425858.
17. Johansson GM, Häger CK. A modified standardized nine Hole Peg test for valid and reliable kinematic assessment of dexterity post-stroke. *J Neuroeng Rehabil* 2019;16:8.
18. Martin-Martin J, Cuesta-Vargas AI. Quantification of functional hand grip using electromyography and inertial sensor-derived accelerations: Clinical implications. *Biomed Eng Online* 2014;13:161.

19. Lemmens RJ, Janssen-Potten YJ, Timmermans AA, Smeets RJ, Seelen HA. Recognizing complex upper extremity activities using body worn sensors. *PLoS One* 2015;10:e0118642.
20. Bowler M, Amirabdollahian F, Dautenhahn K. Using an embedded reality approach to improve test reliability for NHPT tasks. *IEEE Int Conf Rehabil Robot* 2011;2011:5975343.
21. Available from: <https://www.performhealth.com.au/Product/info/PAT-A8515>. [Last accessed on 2021 Jan 11].
22. Earhart GM, Cavanaugh JT, Ellis T, Ford MP, Foreman KB, Dibble L. The 9-hole PEG test of upper extremity function: Average values, test-retest reliability, and factors contributing to performance in people with Parkinson disease. *J Neurol Phys Ther* 2011;35:157-63.
23. Bazgir O, Habibi SAH, Palma L, Pierleoni P, Nafees S. A classification system for assessment and home monitoring of tremor in patients with Parkinson's Disease. *J Med Signals Sens* 2018;8:65-72.
24. Brunner IC, Skouen JS, Strand LI. Recovery of upper extremity motor function post stroke with regard to eligibility for constraint-induced movement therapy. *Top Stroke Rehabil* 2011;18:248-57.