

Design and Development of a Low-Cost Arduino-Based Electrical BioImpedance Spectrometer

Abstract

Background: Bioimpedance spectroscopy (BIS) is a device used to measure electrical impedance at frequencies from 0 Hz to 1 MHz. Many clinical diagnosis and fundamental researches, especially in the field of physiology and pathology, rely on this device. The device can be used to estimate human body composition, through the information of total body water, extracellular fluid and intracellular fluid, fat-free mass, and fat mass from its impedance. BIS analysis can provide physiological statuses such as ischemia, pulmonary edema, skin cancer, and intramuscular tumors. BIS is expected to be used even more widely, both for hospital or home-based use, particularly because BIS handy, compact, inexpensive, and less power-consuming with adequately accurate real-time. In previous research, the BIS design was based on the magnitude-ratio and phase-difference detection using the AD8302 gain-phase detector method which resulted in an operating range between 20 kHz and 1 MHz. However, the impedance was obtained from the logarithmic ratio magnitude which caused the device to have limited accuracy at frequencies <20 kHz. **Methods:** In this research, we conduct design and development of a low-cost arduino-based electrical bioimpedance spectrometer. **Results:** The low-cost bioimpedance spectrometry was successfully developed using AD9850 as the programmable function generator, OPA2134 as the OpAm of voltage-controlled current source, AD620A as the instrument amplifier and AD536A as the alternating current to direct current converter which could work accurately from 0 Hz to 100 kHz. **Conclusion:** The multi-frequency bioimpedance device developed in this research has the capability to safely measure the impedance of the human body due to its relatively stable electric current, which is equal to (0.370 ± 0.003) mA with frequencies ranging from 5 to 200 kHz and has an accuracy of over 90% in the frequency range of 10 Hz to 100 kHz.

Keywords: *Arduino based, electrical bioimpedance, low-cost, spectrometer*

Submitted: 20-May-2019

Revised: 24-Jul-2019

Accepted: 20-Nov-2019

Published: 25-Apr-2020

Introduction

Bioimpedance spectroscopy device (BIS) is a device used to measure electrical impedance ranging from 0 Hz to 1 MHz. This device is essential for clinical diagnosis and fundamental researches, especially in physiology and pathology. This device can be used to estimate human body compositions, through information on total body water, extracellular fluid and intracellular fluid, fat-free mass, and fat mass from its impedance data.^[1-3] BIS analysis is capable of giving immense amount of helpful information on physiological conditions such as lymphedema,^[4] pulmonary edema,^[5] diabetic,^[6] tongue cancer,^[7] ischemia,^[8] skin cancer,^[9] and intramuscular tumors.^[10] Since there is an increasing demand of BIS usage in both hospitals and homes, it is desirable

to advance an improvement for a more practical BIS. BIS measurement devices that are handy, compact, inexpensive, less power-consuming with adequately accurate real-time is considered necessary. The AD6302 gain-phase detector method was used in previous research a basis to perform magnitude-ratio and phase-difference detection that was useful in determining the BIS design. The device has an operating area between 20 kHz and 1 MHz. Determination of Z was obtained from the magnitude of the logarithmic ratio which caused limited accuracy at frequencies of <20 kHz.^[11-13] A different researcher used AD5933^[14] as the basis to obtain bioimpedance. The AD5933 is a high precision impedance converter system that combines 12-bit frequency generator and 1 (MSPS) Mega sampling per second analog-to-digital converter (ADC) on board. The response signal of impedance was sampled by ADC meanwhile discrete

This is an open access journal, and articles are distributed under the terms of the Creative Commons Attribution-NonCommercial-ShareAlike 4.0 License, which allows others to remix, tweak, and build upon the work non-commercially, as long as appropriate credit is given and the new creations are licensed under the identical terms.

For reprints contact: reprints@medknow.com

How to cite this article: Ain K, Wibowo RA, Soelistiono S, Muniroh L, Ariwanto B. Design and development of a low-cost arduino-based electrical bioimpedance spectrometer. *J Med Signals Sens* 2020;10:125-33.

Khusnul Ain¹,
R. Arif Wibowo²,
Soegianto
Soelistiono¹,
Lailatul Muniroh³,
Bayu Ariwanto²

¹Biomedical Engineering,
²Physics, Faculty of Science and
Technology, ³Nutrition Science,
Faculty of Public Health,
Airlangga University, Surabaya,
Indonesia

Address for correspondence:
Dr. Khusnul Ain,
Biomedical Engineering Study
Program, Faculty of Science
and Technology, Universitas
Airlangga, Surabaya, Indonesia.
E-mail: k_ain@fst.unair.ac.id

Access this article online

Website: www.jmssjournal.net

DOI: 10.4103/jmss.JMSS_24_19

Quick Response Code:



Fourier transform (DFT) was processed by digital signal processing engine. The DFT algorithm produced real (R) and imaginary (I) data which was used to calculate the impedance and phase; however, it could only measure impedance values ranging from 0 to 100 kHz.

The purpose of this study is to develop a low-cost arduino-based bioimpedance spectrometry device for the human body that can work accurately at frequency ranging from 0 to over 100 kHz.

Materials and Methods

Figure 1 gives an overall explanation about the structure of the multi-frequency bioimpedance system. The system consisted of a function generator, a block direct current (DC), a voltage-controlled current source (VCCS), an ampere-meter, a voltmeter, an alternating current (AC) to DC converter and a microcontroller.

The ammeter was built from a current to voltage circuit using the AD620 while AD620 was used by the voltmeter as an instrumentation amplifier. AD9850 module was used by the function generator controlled by microcontroller (Arduino). The AD9850 is a highly device that uses advanced direct digital synthesis technology coupled with an internal high speed, high performance, D/A converter and comparator, to form a complete digitally programmable frequency synthesizer and clock generator function. The Arduino controlled frequency of the AD9850 module using serial data. The Schematic of AD9850 circuit with Arduino is shown in Figure 2 while the program code can be seen in Figure 3. As the result, the device was of generating a sine wave of DC signals ranging from 0 Hz upto 40 MHz.

The DC block was basically a high pass filter, using 10 kΩ resistors and 10 nF capacitors, resulting in a cutoff

frequency of 1.6 kHz. The DC block was useful for sliding down a DC sine wave so that it becomes an AC sine wave. The VCCS has the ability to produce a constant current requiring a potential sine wave as the input. The integrated circuit (IC) used to build the VCCS was the dual op-am OPA2134. Ampere meters and voltmeters were built from an AD620 instrument amplifier. The AC to DC converter was built from an AD536. It converts an Rms AC into DC voltage that is ready to be read by the ADC port of microcontroller.

It is necessary to study each of several components above to gain comprehensive information. The important components studied consisted of Function Generator, Block DC, VCCS, Ampere-meter, Voltmeter, and AC to DC converter. With the aim of testing the AD9850 module, the activation of microcontroller was crucial so that frequency signals from 0 to 40 MHz could be produced. Further analysis and observation were performed to the signal output of the AD9850 module using an oscilloscope. Afterward, the relationship curve between the frequencies was applied to V_{rms} . To run tests for the DC block, the DC signal from the AD9850 module was inputted and the output was then examined using the oscilloscope with frequency range of 1 Hz to 100 kHz. After that, an observation was carried out to determine whether the DC signal changed into AC signal and whether the curve of the relationship between the frequencies of V_{rms} was seen. The test of VCCS performance was done at load of the variable resistor. Before the test was finally conducted, the frequencies were set at 10 kHz, 100 kHz, and 1 MHz. At each of those frequencies, the authors determine the correlation curve between load variations and the electrical currents produced by VCCS. The authors also used an instrument amplifier as an ampere meter and voltmeter. In order to test the instrument amplifier's capability, the authors exerted AC voltage signals and connected it to the two input channels. A curve was then seen after observing the output voltage channel, which signified correlation between the input signal and the output signal. An AC voltage signal input was arranged to conduct performance test of the AD536A. Afterward, the observation towards the resulting Rms DC voltage was performed prior to comparing it to the Rms input signal.

Furthermore, all components were assembled into multi-frequency bioimpedance systems and tested using R, C, RC series, RC parallel, R series with RC parallel, and C series with RC parallel. The program code used to obtain information of impedance versus frequency is shown in Figure 4.

Data retrieval was carried out at frequencies ranging from 10 kHz to 300 kHz. The resistor used was 1 kΩ and the nonpolar capacitor used was 10 nF. Furthermore, the multi-frequency bioimpedance system was used to measure each of impedance models as well as to compare calculations.

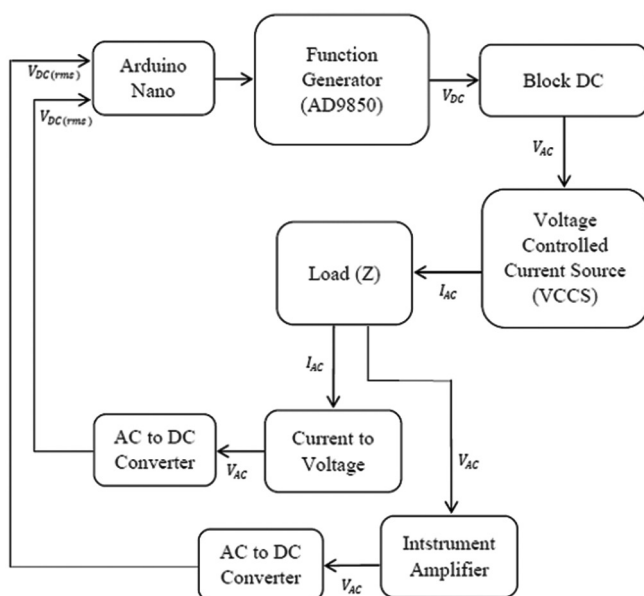

Figure 1: The block diagram of multi frequency bio-impedance device based on an arduino

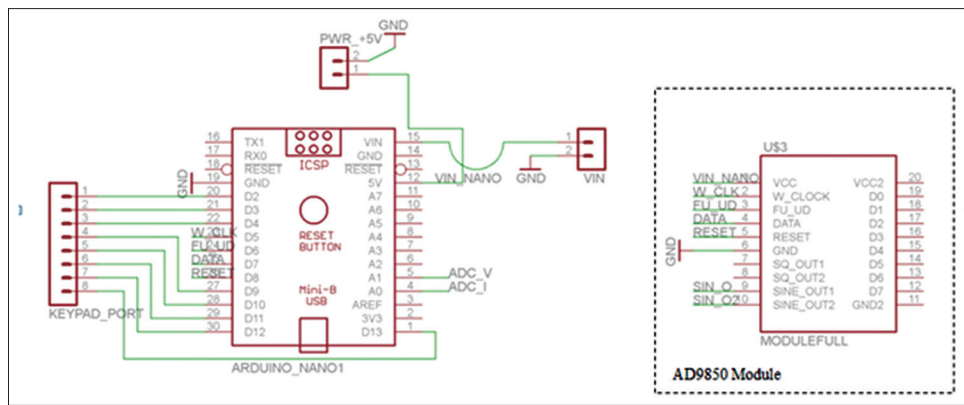

Figure 2: Schematic of AD9850 circuit with Arduino

Results

The AD9850 function generator was able to produce DC signals with V_{rms} of 600 mV at 1 kHz to 1 MHz. Meanwhile, the V_{rms} dropped according to the specifications of the maximum frequency of 40 MHz as shown in Figure 5. In addition, the High Pass Filter or the block DC stopped the DC voltage to become an AC signal. In addition to blocking DC signals, High Pass Filter was also used to block frequency signals <1 kHz, as shown in Figure 5.

The VCCS used in this study was the multiple Op-Amp VCCS. This VCCS used feedback in order to get a stable output. If V_{rms} of AD9850 function generator is 600 mV with formula $I_L = -V_{IN} \frac{R_f}{R_s R_1}$ and $R_f = R_s = R_1 = 2$ k Ω ,

theoretically it will produce 0.3 mA. At 10 kHz, the VCCS produced a stable current of 0.36 mA with a maximum load of 6 k Ω , then the current decreased to 0.31 mA at a load of 10 k Ω . At 100 kHz the current from the load 0 Ω to 10 k Ω dropped from 0.35 mA to 0.18 mA. At 1 MHz the current from loads 0 to 3415 Ω decreased to 0.051 mA. The resulting VCCS characteristics are shown in Figure 6. The analysis At 10 kHz and 100 kHz frequencies showed that the current could be used safely because it is still in the range of 0.05 mA to 0.5 mA. However, at 1 MHz when the load was more than 341 Ω , the electrical current was <0.05 mA. This means that it cannot be used due to the small voltage generated, which may affect the impedance readings of Arduino. As a result, readings tend to be inaccurate.

The design of the developed multifrequency bioimpedance device is shown in the schematic based on the test of each module. Figure 7 shows the VCCS, current to voltage and AC to DC, Figure 8 shows the voltmeter circuit with AD620 and RMS to DC, shows the AD9850 circuit with Arduino, Figure 9 shows a multi-frequency bioimpedance device, and Figure 10 shows the hardware picture.

The result of the R impedance test with 1 k Ω is shown in Figure 11. It reveals that an error of more than 10% occurred at frequencies above 280 kHz.

The load impedance C used in the test was 10 nF. Theoretically, the magnitude of the impedance on capacitor C is $Z = 1/2 \pi fC$. The comparison between measured impedance and theory is presented in Figure 12 which shows that frequencies of more than 110 kHz, the error found is above 10%.

The impedance test of the RC Serial circuit used $R = 1$ k Ω and $C = 10$ nF. The equation used to measure the RC

Serial is $Z = \sqrt{R^2 + \left(\frac{1}{2\pi fC}\right)^2}$. The comparison between

theoretical and measured impedance is shown in Figure 13. The error percentage reached more than 10% when the frequencies were more than 160 kHz.

Furthermore, the RC parallel test used $R = 1$ k Ω and $C = 10$ nF. The equation to measure of parallel RC

impedance is $Z = \frac{R \frac{1}{2\pi fC}}{\sqrt{R^2 + \left(\frac{1}{2\pi fC}\right)^2}}$. The comparison

between theory and measurements can be seen in Figure 14. At frequencies above 120 kHz, percentage of error reached more than 10%.

The test of R Serial with RC parallel used $R = 1$ k Ω and $C = 10$ nF. In theory, the equation used to measure the impedance of R Serial with RC parallel is

$Z = R + \frac{R \frac{1}{2\pi fC}}{\sqrt{R^2 + \left(\frac{1}{2\pi fC}\right)^2}}$. Figure 15 displays the

comparison between the theoretical impedance and the measurement obtained. It shows that the frequency was unstable and inaccurate when frequencies were more than 110 kHz.

The impedance test of C serial with parallel RC used $R = 1$ k Ω and $C = 10$ nF. It took two Cs and one R with RC parallel with C serial. The impedance calculation of C serial with RC

```

void loop() {
  adc0=0;
  adc1=0;
  adc2=0;
  adc3=0;
  if (Serial.available ()>0)
  { numerik=0;
  while(1) {
    datachar=Serial.read();
    if (datachar=='\n')break;
    if(datachar== -1) continue;
    numerik *=10;
    numerik=((datachar-'0')+numerik);
    frek= (numerik/10+3.5);
  }
  sendFrequency(frek);
  delay(50);
  adc0=analogRead(A0);
  delay(50);
  adc1=analogRead(A1);
  delay(50);
  adc_v=(adc1 * (5.00/1023))/1.99;
  adc_i=adc0 * (5.00/1023);
  Imp=(adc_v/adc_i) * 996;
  Serial.println(Imp);
  delay(50);
}
}

```

Figure 3: The Program code to control AD9850 module

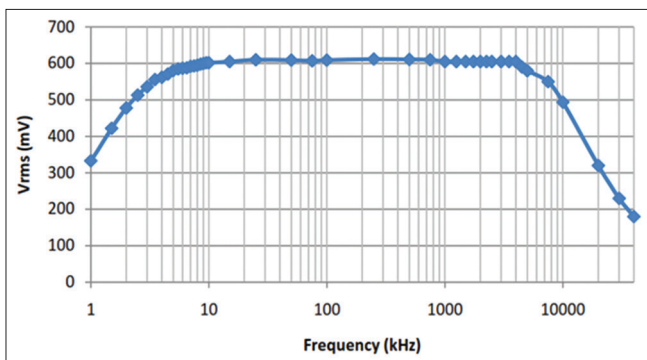

Figure 5: V_{rms} versus frequency was produced by AD9850

parallel based on theory is
$$Z = \frac{1}{2\pi fC} + \frac{R}{\sqrt{R^2 + \left(\frac{1}{2\pi fC}\right)^2}}$$

Theoretical impedance that was compared to the measurement impedance results can be seen in Figure 16. Analysis based on the results of the tool revealed that the C serial with RC parallel impedance theory tended to approach each other with inaccurate and unstable frequency when the frequency reached more than 120 kHz.

```

sendFrequency(frek);
delay(50);
adc0=analogRead(A0);
delay(50);
adc1=analogRead(A1);
delay(50);
adc_v=(adc1 * (5.00/1023))/1.99;
adc_i=adc0 * (5.00/1023);
Imp=(adc_v/adc_i) * 996;
Serial.println(Imp);
delay(50);
}
}

```

Figure 4: The program code to get impedance from I to V data

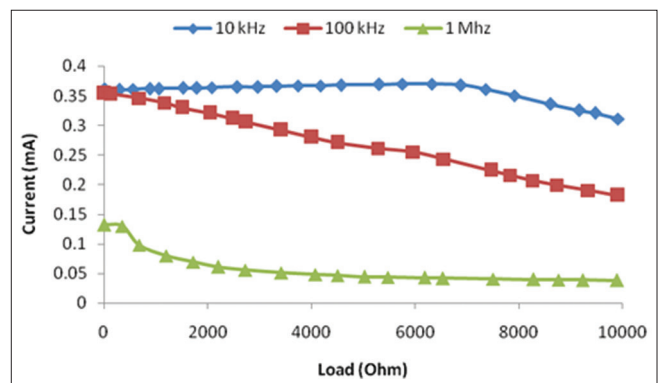

Figure 6: Electrical current characteristics of the double op-amp OPA2134 voltage controlled current source

The R parallel with RC serial test used $R = 1 \text{ k}\Omega$ and $C = 10 \text{ nF}$. The model equation of R parallel with RC

serial is
$$Z = \frac{R_e \sqrt{R_i^2 + \left(\frac{1}{2\pi fC_m}\right)^2}}{\sqrt{R_i^2 + \left(\frac{1}{2\pi fC_m}\right)^2} + R_e}$$
. The difference

between theory and measured impedance can be seen in Figure 17. Frequencies more than 280 kHz did not produce accurate and stable results.

Several tests had frequency limits before producing errors of more than 10%. The component R started to become unstable at 280 kHz; while the component C was unstable at 110 kHz; the RC serial at 160 kHz; the RC parallel at 180 kHz; the R serial with RC parallel at 110 kHz; the C parallel with RC serial at 120 kHz; and the R parallel with RC series at 280 kHz. The device accuracy at 100 kHz to 200 kHz was able to be improved by adding an amplifier to the voltage measurement so that the frequency range was wider if compared to bioimpedance measurements using IC AD5933.

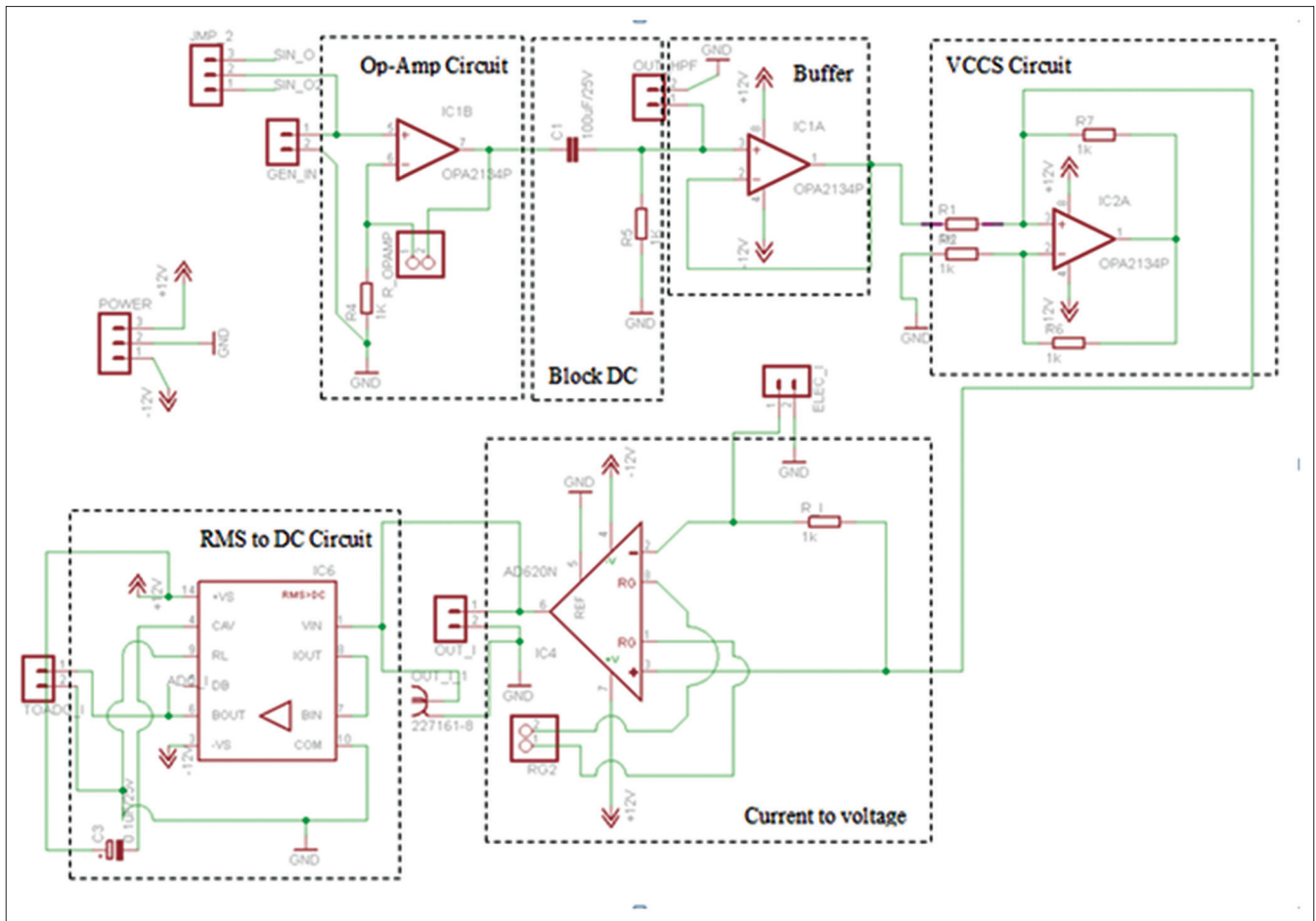

Figure 7: Schematic of voltage controlled current source, current to voltage and RMS to direct current

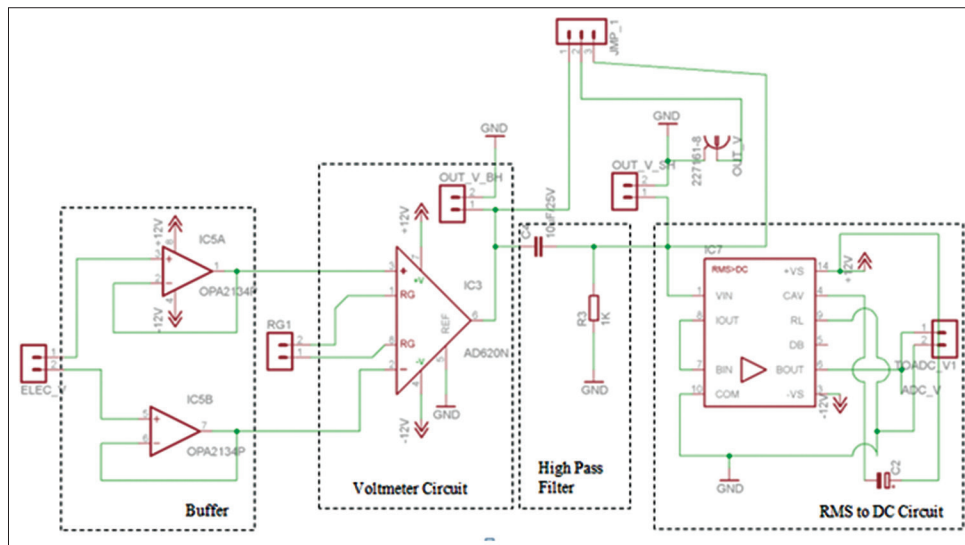

Figure 8: Schematic of voltmeter circuit with AD620 and RMS to direct current

This device has the capability to measure the impedance of the human body safely due to its relatively stable electric current produced which is equal to (0.370 ± 0.003) mA at 5–200 kHz, as shown in Figure 18. The electric

current generated is in the safe category range from the danger of macroshock. Meanwhile, to avoid the danger of microshock, measurements are made by placing the electrodes on the hands and feet on one side of the body.

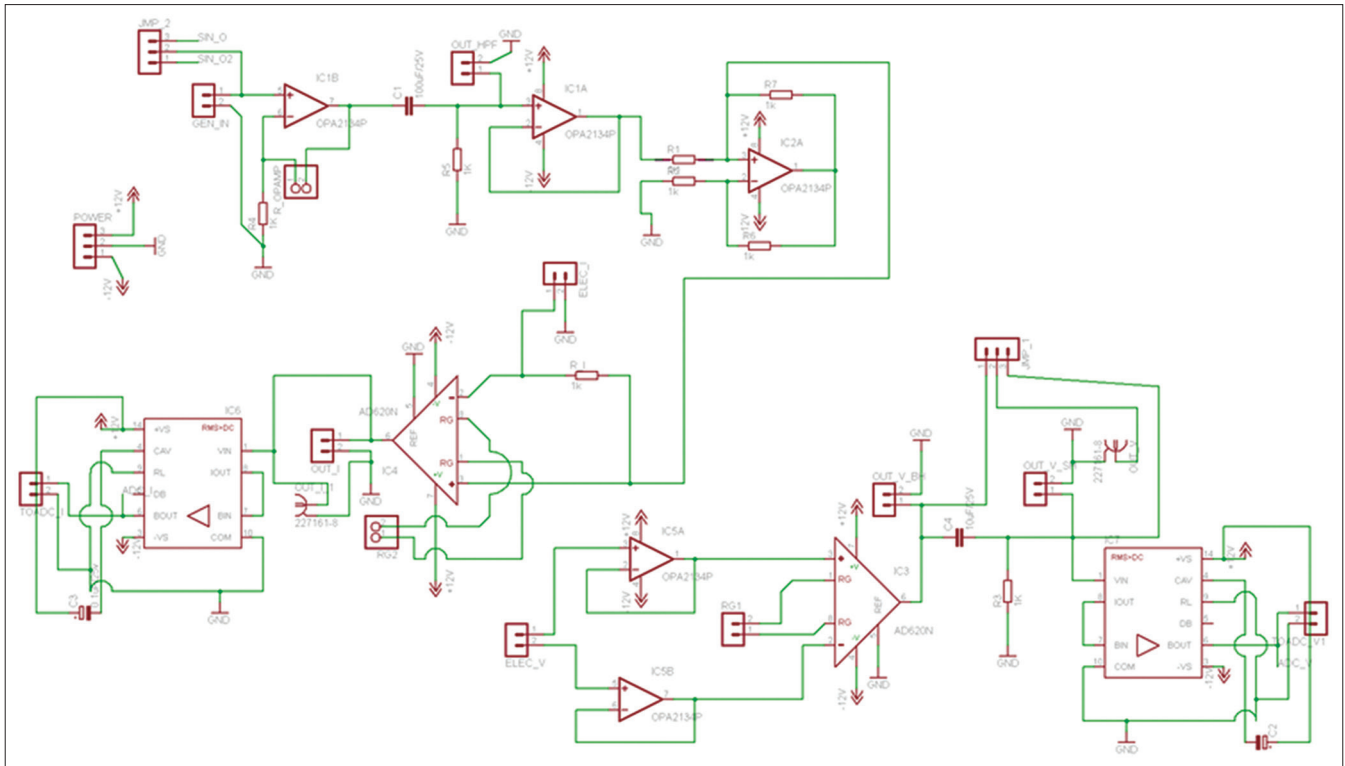

Figure 9: Schematic of multi-frequency bio-impedance device

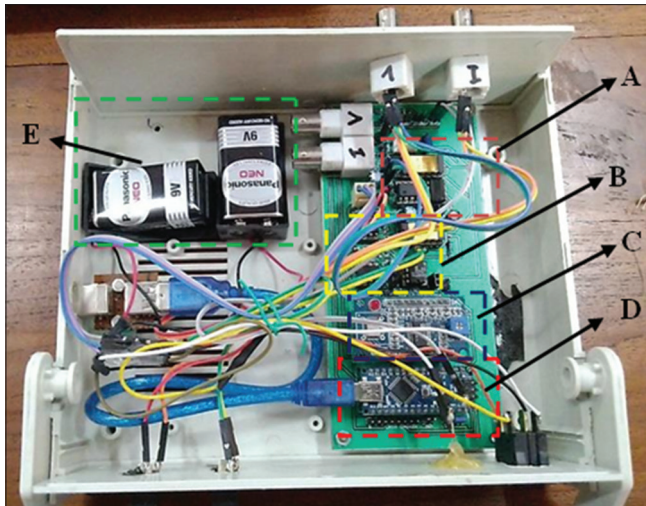

Figure 10: Picture of multi-frequency bio-impedance device (A – Buffer, high pass filter, RMS to direct current, voltmeter circuit; B – Op-amp, block direct current, buffer, voltage controlled current source, current to voltage, RMS to direct current circuit; C – AD 9850; D – Arduino Nano, E – Battery 9 volt)

The results of body bioimpedance measurements of nine objects revealed a bioimpedance spectrum from 5 kHz to 200 kHz which is displayed in Figure 19. It appeared that at 0–100 kHz, the device produced more contrast bioimpedance compared to frequencies higher than 100 kHz.

According to the test variation results, the smallest frequency limit was reached so that it resulted in an error of more than 10%. The smallest frequency that produced

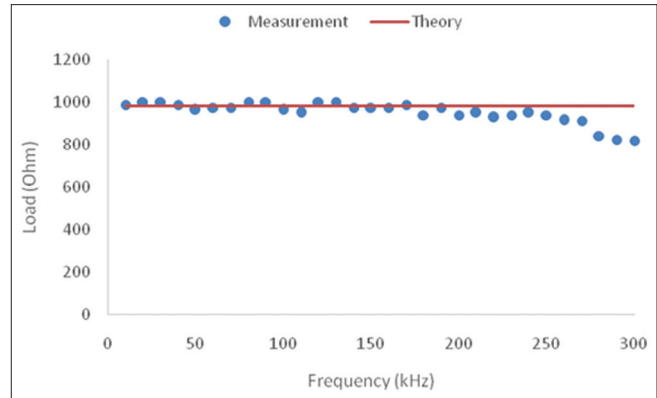

Figure 11: Impedance spectrum of R

an error of more than 10% was equal to 110 kHz. This device performs best when the frequency of 100 kHz is used as the maximum limit. The recommended frequency range of this device is between 10 Hz to 100 kHz. The frequency of 10 Hz was taken because the AD9850 IC module could not generate signals with frequencies under 10 Hz.

Conclusions

1. The developed multi-frequency bioimpedance device was composed of AD9850 module as the controllable sinus generator, high pass filter as the DC block, VCCS to produce a constant current, AD620A as the instrument amplifier, and AD536A as the AC to DC converter

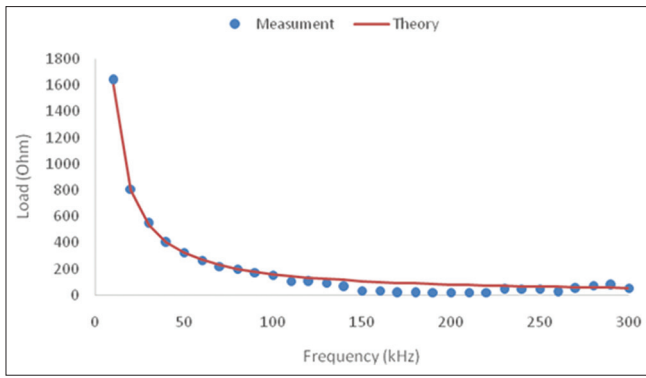

Figure 12: Impedance spectrum of C

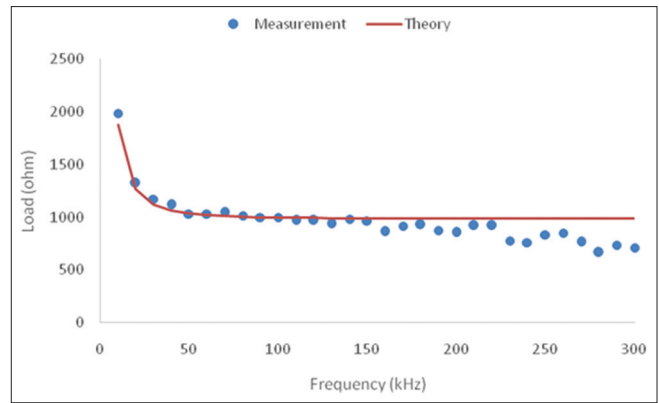

Figure 13: Impedance spectrum of RC serial

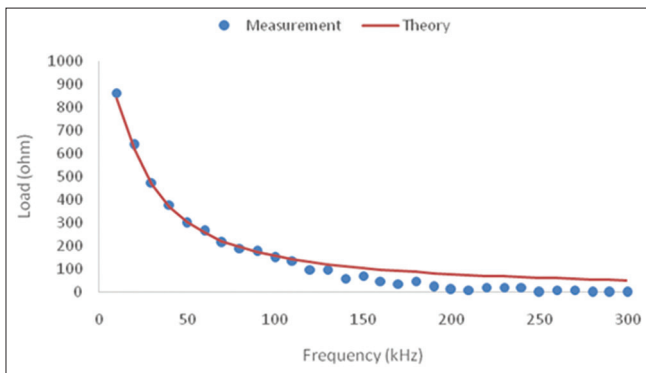

Figure 14: Impedance spectrum of RC parallel

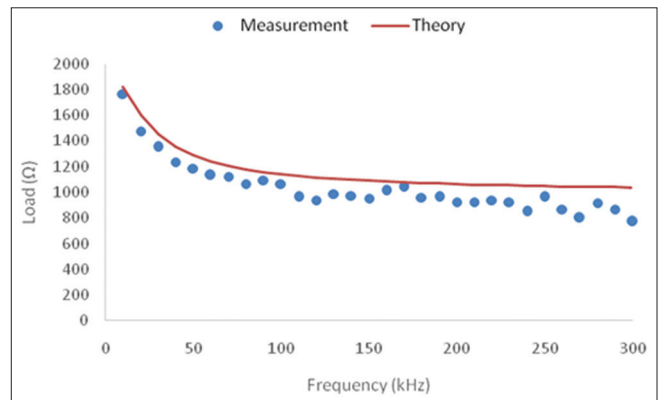

Figure 15: Impedance spectrum of R serial with RC parallel

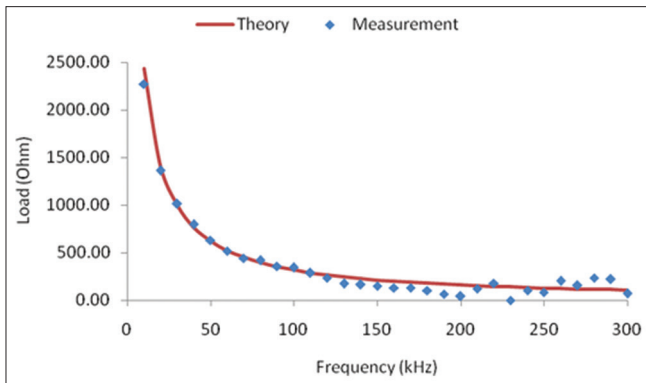

Figure 16: Impedance spectrum of C serial with RC parallel

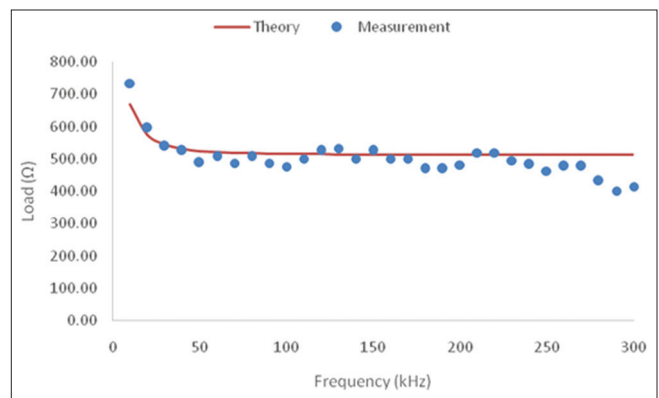

Figure 17: Impedance spectrum of R parallel with RC serial

2. The AD9850 module was able to produce stable V_{rms} up to 1 MHz of frequency range, the high pass filter successfully filtered frequency signals <1.6 Hz so that the DC signal from the AD9850 module could be shifted down into AC signal. In addition, the VCCS circuit was able to produce a stable current over 0.05 mA at 10 kHz and 100 kHz whereas at 1 MHz it produced a current of <0.05 mA. The instrumentation amplifier test results showed that the input signal and the output signal tend to be linear at 10 kHz to 100 kHz, and the AC to DC converter was able to convert the input AC signal into good V_{rms} at 10 kHz and 100 kHz

3. The multi-frequency bioimpedance device developed for the human body has the capability in safely measuring the impedance of human body due to its relatively stable electric current which is equal to (0.370 ± 0.003) mA at 5–200 kHz and has signal accuracy of more than 90% in frequencies ranging between 10 Hz to 100 kHz.

Acknowledgment

The authors would like to express gratefulness to the Indonesian Ministry of Research and high education

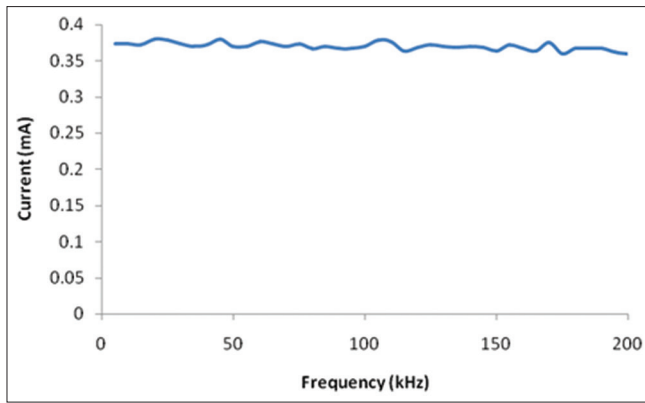

Figure 18: Electrical current in contrast with frequencies when used in the measurement of the bio-impedance of the human body

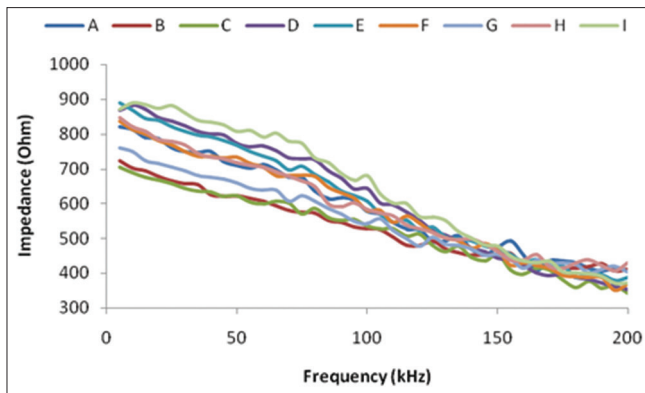

Figure 19: Bio-impedance data of nine objects from devices 5 kHz to 200 kHz

forfunding this research through the PDUPT Project No. 711/UN3.14/LT/2019.

Financial support and sponsorship

None.

Conflicts of interest

There are no conflicts of interest.

References

- Gómez-Ambrosi J, González-Crespo I, Catalán V, Rodríguez A, Moncada R, Valentí V, *et al.* Clinical usefulness of abdominal

- bioimpedance (ViScan) in the determination of visceral fat and its application in the diagnosis and management of obesity and its comorbidities. *Clin Nutr* 2018;37:580-9.
- Costa RF, Cyrino ES. Vertical segmental tetrapolar bioimpedance for excess body fat assessment in adolescents. *J Pediatr (Rio J)* 2016;92:319-20.
- Abbas SR, Thijssen S, Penne EL, Raimann JG, Liu L, Sipahioglu MH, *et al.* Effect of change in fluid status evaluated by bioimpedance techniques on body composition in hemodialysis patients. *J Ren Nutr* 2018;28:183-90.
- Qin ES, Bowen MJ, Chen WF. Diagnostic accuracy of bioimpedance spectroscopy in patients with lymphedema: A retrospective cohort analysis. *J Plast Reconstr Aesthet Surg* 2018;71:1041-50.
- Mayer M, Brunner P, Merwa R, Scharfetter H. Monitoring of lung edema using focused impedance spectroscopy: A feasibility study. *Physiol Meas* 2005;26:185-92.
- Prado-Olivarez J, Arellano-Olivares F, Padilla-Medina J, Diaz-Carmona A, Ramirez-Agundis A, Espinosa-Calderon M, *et al.* Bioimpedance phase angle analysis of foot skin in diabetic patients: An experimental case study. *IRBM* 2015;36:233-9.
- Sun TP, Ching CT, Cheng CS, Huang SH, Chen YJ, Hsiao CS, *et al.* The use of bioimpedance in the detection/screening of tongue cancer. *Cancer Epidemiol* 2010;34:207-11.
- Kun S, Ristić B, Peura RA, Dunn RM. Algorithm for tissue ischemia estimation based on electrical impedance spectroscopy. *IEEE Trans Biomed Eng* 2003;50:1352-9.
- Aberg P, Nicander I, Hansson J, Geladi P, Holmgren U, Ollmar S. Skin cancer identification using multifrequency electrical impedance-a potential screening tool. *IEEE Trans Biomed Eng* 2004;51:2097-102.
- Skourou C, Hoopes PJ, Strawbridge RR, Paulsen KD. Feasibility studies of electrical impedance spectroscopy for early tumor detection in rats. *Physiol Meas* 2004;25:335-46.
- Yang Y, Wang J, Yu G, Niu F, He P. Design and preliminary evaluation of a portable device for the measurement of bioimpedance spectroscopy. *Physiol Meas* 2006;27:1293-310.
- Mohamadou Y, Momo F, Theophile L, Njike Kouekeu Landry C, Fabrice T, Emmanuel S. Accuracy enhancement in low frequency gain and phase detector (AD8302) based bio-impedance spectroscopy system. *Measurement* 2018;123:304-8.
- Mylott E, Kutschera E, Widenhorn R. Bioelectrical impedance analysis as a laboratory activity: At the interface of physics and the body. *Am J Phys* 2014;82:521-8.
- Kamat D. K, Bagul D, and Patil P. M. Blood glucose measurement using bioimpedance technique. *Advances in Electronics* 2014;2014:4-9.

BIOGRAPHIES



Khusnul Ain is a lecturer in Bachelor of Biomedical Engineering, Department of Physics, Faculty of Science and Technology, Airlangga University, Indonesia. He got his bachelor, master, and doctoral degree from Gadjah Mada University majoring Nuclear Engineering, Physics, and Bandung Institute of Technology majoring Physics

Engineering. All of them are in Indonesia. His research field are tomography and spectroscopy of electrical bioimpedance.

Email: k_ain@fst.unair.ac.id



R. Arif Wibowo is a lecturer in Bachelor of Physics Department, Faculty of Science and Technology, Airlangga University, Indonesia. He got his bachelor and master degree from Airlangga University majoring Physics and Gadjah Mada University majoring Physics. All of them are in Indonesia. His research field are theoretical physics.

Email: aa.arifwr@gmail.com



Soegianto Soelistono is a lecturer in Bachelor of Biomedical Engineering, Department of Physics, Faculty of Science and Technology, Airlangga University, Indonesia. He got his bachelor, master, and doctoral degree from Institut Teknologi Sepuluh Nopember majoring Physics and Institut Teknologi Bandung majoring Physics. All of them are in Indonesia. His research field are computational physics and artificial intelligence.

Email: soegianto@fst.unair.ac.id



Lailatul Muniroh is a lecturer in Nutrition Science, Faculty of Public Health, Airlangga University, Indonesia. She got her Bachelor and master degree from Airlangga University majoring Public Health. Her research field are nutrition science.

Email: lailamuniroh@fkm.unair.ac.id



Bayu Ariwanto is a researcher in Bachelor of Physics Department, Faculty of Science and Technology, Airlangga University, Indonesia. He got his bachelor from Airlangga University majoring Physics. His research field are instrumentation physics.

Email: bayumask3@gmail.com