

Gas Sensor Array System Properties for Detecting Bacterial Biofilms

Abstract

Background: Gas sensor array system is a device that mimics the work of how the nose smells using the gas sensors that could give response toward specific odors. It is used for characterizing the different blended gas that is suited with the biological working nose principle. Thus, it could be used to detect the dental and oral diseases. Periodontitis is one of the diseases caused by the damage on the teeth due to the chronic infection on the gingival structure marked with bacterial plaque and calculus. This study aims to develop an electric nose for odor detection application on the periodontal bacterial biofilm as early detection device for dental and oral disease. **Methods:** This device is designed as a portable device to ease the data acquisition. The measured data were stored at a database system connected to a real-time computer. A gas array sensor system with six gas sensors (TGS 826, TGS 2602, TGS 2600, TGS 2611, TGS 2612, and TGS 2620) has been assembled for the early detection application for dental and oral disease excreted by the bacterial biofilm that caused dental and oral disease, including *Aggregatibacter actinomycetemcomitans*, *Porphyromonas gingivalis*, *Streptococcus mutans*, and *Enterococcus faecalis*. **Results:** TGS 826 and TGS 2602 sensor had the best response showed by the high ADC delta value. **Conclusion:** GS 826 and TGS 2602 sensor could be used as a candidate for early detection device for dental and oral disease.

Keywords: Bacterial biofilm, gas array sensor system, gas sensor, TGS 826 and TGS 2602 sensor

Introduction

Gas sensor array system is a device that detects pollutant gases with microcontroller as data processor. The voltage output of every sensor during pollutant gas detection was processed by this microcontroller.^[1] The gas sensor used in the gas sensor array system comprises conductive polymer gas sensor, quartz-microbalance, surface acoustic wave, and oxide metal.^[2] The sample preparation of this gas sensor array system was using a static headspace sensor system. The use of this system aims to decrease the risk of contamination. The static headspace sensor system has two purposes: sensing and purging process.^[3] The sensing process is performed after baseline data acquired for 10 min. The sensor voltage output data is acquired when the sensor is exposed to a specific gas with a sensing time of 30 min. The purging process is performed after the sensing process by releasing the bacteria flask from the sensor. This process aims to obtain a normal environment voltage (air) as a baseline condition. The gas array sensor system could detect a specific gas according to the gas sensor used.

This is an open access journal, and articles are distributed under the terms of the Creative Commons Attribution-NonCommercial-ShareAlike 4.0 License, which allows others to remix, tweak, and build upon the work non-commercially, as long as appropriate credit is given and the new creations are licensed under the identical terms.

For reprints contact: reprints@medknow.com

Gas sensor array system has been already applied in several fields, such as food, beverage, chemical industry, defense, and medical field.^[4] In medical field, it was already developed for invasive diagnosis of ventilator-associated pneumonia.^[5] The problem in dental and oral health is usually not prioritized by most people. Commonly, they know that teeth and mouth are the gate for viruses or bacteria that could affect their health, especially in periodontal tissue.^[4] The dental and oral diseases are initiated by the presence of progressive bacterial infection. The bacteria on the dental plaque forms a colony in gingival tissue that cause inflammation response of the supportive tissue in the teeth.^[6]

Periodontitis is one of the diseases caused by the damage on the teeth due to chronic infection on the gingival structure and marked by the bacterial plaque and calculus formation.^[7] Several anaerobe species in the mouth cavity that has been cultured are *Porphyromonas gingivalis* (Pg), *Bacteroides gracilis*, *Bacteroides oralis*, *Bacteroides buccae*, *Eikenella corrodens*, *Fusobacterium nucleatum*, *Prevotella intermedia*, *Fusobacterium*

How to cite this article: Astuti SD, Mukhammad Y, Duli SA, Putra AP, Setiawatie EM, Triyana K. Gas sensor array system properties for detecting bacterial biofilms. *J Med Signals Sens* 2019;9:158-64.

Received: December, 2018. **Accepted:** February, 2019.

Suryani Dyah Astuti^{1,2},
Yanuar Mukhammad¹,
Sirlus Andreanto Jasman Duli¹,
Alfian Pramudita Putra²,
Ernie Maduratna Setiawatie³,
Kuwat Triyana⁴

¹Biomedical Engineering, Postgraduate School,

²Department of Physics, Faculty of Science and Technology,

³Department of Periodontics,

Faculty of Dentistry, Universitas Airlangga, Surabaya,

⁴Department of Physics,

Faculty of Mathematics and

Natural Science, Gadjah

Mada University, Yogyakarta,

Indonesia

Address for correspondence:

Dr. Suryani Dyah Astuti,
Department of Physics, Faculty of Science and Technology,
Universitas Airlangga,
Surabaya, Indonesia.

E-mail: suryanidyah@fst.unair.ac.id

Access this article online

Website: www.jmssjournal.net

DOI: 10.4103/jmss.JMSS_60_18

Quick Response Code:



necrophorum, *Aggregatibacter actinomycetemcomitans* (Aa), *Peptostreptococcus*, *Enterococcus faecalis* (Ef), *Clostridium*, and *Actinomyces*.^[4] The diagnosis of periodontal disease consists of history analysis and clinical symptoms comprising several evaluations, such as dental shakiness evaluation, radiography, blood test, and biopsy for problem identification of the patient.^[8] Based on the information mentioned before, it is needed to have an early noninvasive detection for dental and oral diseases. Gas array sensor system is expected to be a candidate for a noninvasive detection of dental and oral disease with good performance.

The microorganisms that stay in the mouth cavity produce unpleasant oral odor substances, such as volatile sulfur that represents 90% of oral cavity atmosphere (methyl mercaptan [CH₃SH], hydrogen sulfide [H₂S], and dimethyl sulfide [CH₃SCH₃]), short chain fatty acid (butyrate acid, valerate acid, and propionic acid), and polyamine (putrescine and cadaverine).^[9]

Hydrogen sulfide (H₂S) is commonly known as a toxic gas with rotten egg odor,^[10] which is resulted from bacterial decomposition of subgingival pocket.^[11,12] This disease could be seen from the inflammation condition marked by the damage in connective tissue, attachment lose, and alveolar bone resorption.^[13]

This study aimed to develop a gas sensor array system for odor detection application on the bacterial biofilm of periodontal disease as a candidate of an early detection device for dental and oral disease. A gas sensor array system with gas sensors TGS 826, TGS 2602, TGS 2600, TGS 2611, TGS 2612, and TGS 2620 was designed as a portable device, so that it is easy for data acquisition. The data were measured and stored in a database system connected to a computer in a real-time condition.

Materials and Methods

Gas sensor array system design

Gas sensor array system is a device that is developed to detect odor and characterize the combination of gases forming the odor. The instrumentation design of gas sensor array system is shown in Figure 1.

TGS gas sensor consists of three parts, such as sensing element, sensor base, and sensor cap.^[14] The material of sensing element of TGS gas sensor is metal oxide, such as SnO₂.^[1] Figure 2 shows the TGS sensor design. There is a heater inside the sensor that has function as a heating sensing material that could work optimally in temperature between 300°C and 550°C.^[15] At low temperature, the reaction rate on the oxide metal surface is so slow. Thus, the metal oxide should be heated to catch more oxygen and become more negative. The electron from the metal oxide was delivered to the adsorbed oxygen and left positive charge on the surface layer. This layer could form a positive

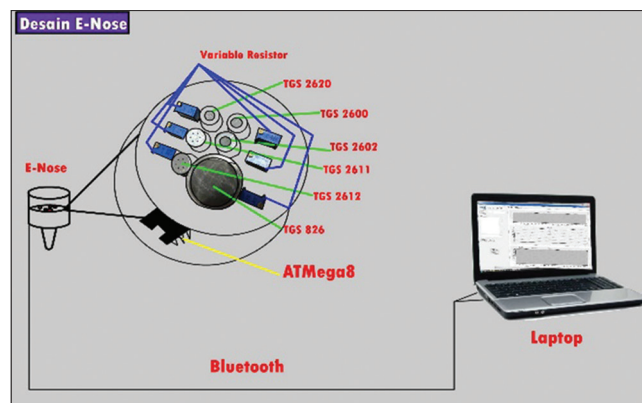

Figure 1: The instrumentation system design of gas sensor array system

charge cover called voltage barrier to inhibit electron flow or current.^[15]

The response produced by gas sensor array system was DC voltage from each sensor. The gas sensor array system device was designed from several electronic components, consisting of gas sensor (Figaro Engineering, Osaka, Japan) TGS 826, TGS 2602, TGS 2600, TGS 2611, TGS 2612, and TGS 2620; variable resistors; microcontroller; ATmega8; and Bluetooth AC-05. The gas sensor array system instrumentation diagram is shown in Figure 3.

The gas sensor array system device had two PCBs originating from white fiber material with a thickness of 2 mm. The first PCB had a diameter of 20 cm to put the gas sensor TGS 826, TGS 2602, TGS 2600, TGS 2611, TGS 2612, and TGS 2620 and several other components. This device had a variable resistor with a resistance of 10 kΩ that was used to control the initial voltage of the sensor (the baseline). The second PCB had a ATmega8 microcontroller with 10-bit ADC that has function as control system for sensor data processing. It also had RS232 serial port that was used to deliver the sensor data to a computer. There was also a USB ASP downloader for microcontroller programming. The sensor voltage characterization aimed to observe the sensor voltage output before the sensing process toward the bacteria. This process was performed for 3 min at room temperature with any gases. The measurement of sensor voltage output on the normal air without any gases was performed for each sensor.

Bacterial biofilm culture

The bacteria causing dental and oral diseases were used, such as Aa, Pg, *Streptococcus mutans* (Sm), and Ef. All the bacteria were supplied from the Faculty of Dentistry, Universitas Airlangga. The making of McFarland standard diagram was used for conversion of the number of bacterial cells with its density to optical density (OD) value. The bacterial culture was conducted using sterile agar media or Tryptic Soy Agar (TSA, a Soybean–Casein Digest Agar; Difco, Sparks, MD, USA) and incubated for 24 h at

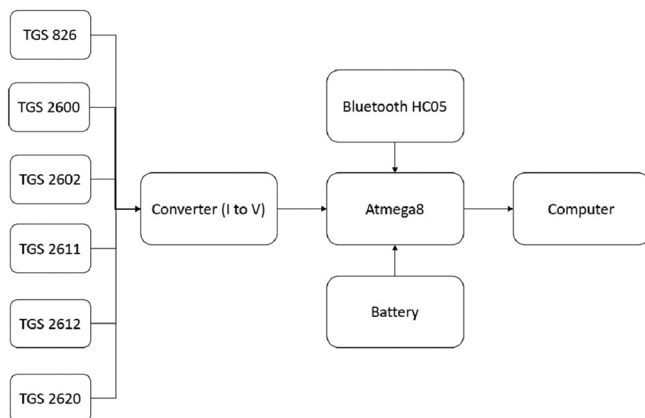

Figure 2: TGS sensor design

temperature of 37°C. After incubation, the sample was put on the microplate wells about 100 µl using a micropipette. The analysis was performed after 30 min for each bacterium. The initial number of colony-forming units per milliliter (CFU/mL) was estimated by measuring the suspension turbidity with a spectrophotometer and verified using CFU/mL counts on TSA after growth at 37°C for up to 24 h.

After obtaining the McFarland standard diagram, the biofilm of bacteria was cultured using the sterile Tryptic Soy Broth (TSB, a soybean–casein digest medium; Acumedia, Lansing, MI) prepared according to the manufacturer’s instructions and autoclaved at 121°C for 15 min before use. The bacteria solution was vortexed until homogeneous. The bacteria solution was then incubated for 2 h at temperature of 37°C. After incubation, the OD of the solution was measured. The culture solution was added by 2 ml of 2% sucrose and was vortexed again. 100 µl of the bacterial biofilm solution was put on the microplate and was shaken for 4 h. The bacterial biofilm solution was then incubated at temperature of 37°C varying from 1 to 5 days. At the 1st day, the bacterial biofilm was taken and rinsed using 50 µl phosphate-buffered saline solutions for three times to filter the bacterial biofilm and TSB solution. The staining procedure was using 200 µl of 2% violet crystal for 30 min. The bacterial biofilm was then rinsed using deionized water and put at room temperature for drying process for 3 h. The bacterial biofilm was added 100 µl of 33% glacial acetic acid and its OD was measured using ELISA reader (Bio-Rad EIA reader 2550, Richmond, CA, USA) to identify the OD or the microorganism density at wavenumber of 595 nm.

The application of gas array sensor system on bacterial biofilm

The sensor stability was conducted by taking sensor sample in a room condition for 3 min with temperature of 25°C without the presence of the other gases related to the ones produced by biofilm. The sensor response measurement was done on the bacterial biofilm with 10 min baseline model, 30-min sensing, and 10-min purging, as follows.

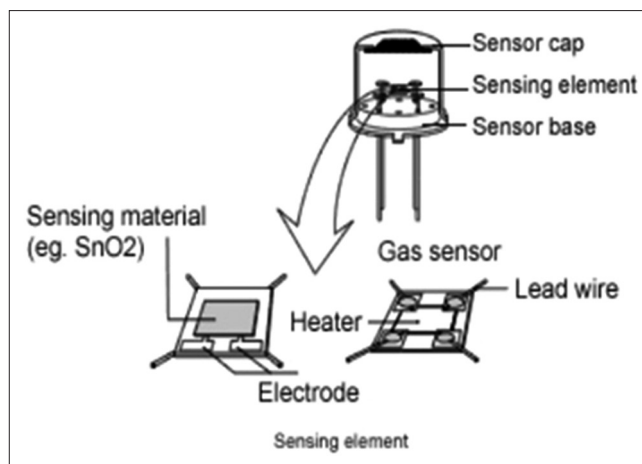

Figure 3: The gas sensor array instrumentation diagram

Baseline value

Baseline value is a sensor output datum without using testing sample (free air). The baseline value was measured for 10 min.

Sensing value

Sensing value is a sensor output datum on the bacterial biofilm sample. It was measured for 30 min.

Purging value

Purging value is a sensor output datum in the condition after the sensing value measurement that was used to return the sensor condition on its stability value. It was measured for 10 min.

The result of this measurement was stored in a user interface application on the database. From that data, the response value of the sensor was recorded in the database application and calculated using Eq. 1.

$$\text{Delta ADC} = \text{Sensing Max Value} - \text{Baseline Value} \quad (1)$$

Delta ADC is a sensor response obtained from the measured biofilm odor. The testing of the biofilm sample was performed for 5 days.

Results and Discussion

The result of ADC value of sensor response characterization is shown in Figure 4. The result of stability test had different baseline value and they were suitable with the TGS gas sensor type that has been used in this study. The difference of that value depended on the control of variable resistor placed on the output of each sensor. The measurement of sensor stability was performed for 3 min at room temperature (25°C). The result after 3 min showed that the sensor could reach the stable point.

The data acquisition of biofilm odor with 30-min sensing and 10-min purging was performed. The sensor response produced by gas sensors TGS 826, TGS 2602, TGS 2600, TGS 2611, TGS 2612, and TGS 2620 was the voltage (mV)

over time sampling. The gas concentration was obtained from several types of gases because the TGS gas sensor is a nonselective gas sensor.

The TGS 2600 gas sensor could detect hydrogen and carbon monoxide gases. The TGS 2611 gas sensor is a sensor that could detect hydrogen and methane gases. The TGS 2612 gas sensor is a sensor that could detect methane, propane, and butane gases. The TGS 2620 gas sensor is a sensor that could detect methane, carbon monoxide, hydrogen, and methanol gases. The TGS 2602 gas sensor is a sensor that could detect ammoniac, hydrogen sulfide, ethanol, and toluene gases. The TGS 826 gas sensor is a sensor that could detect ammoniac and ethanol gases. The measurement of this sensor response toward several types of bacteria each day has increased. That result was illustrated by the change of delta ADC value in Figures 5-10 for TGS 2600, TGS 2611, TGS 2612, TGS 2620, TGS 2602, and TGS 826, respectively. Figures 5-10 show that Pg was dominant in giving odor and detected by the gas sensors and then followed by Aa, Sm, and Ef, respectively. The OD value of bacterial biofilm of Aa, Ef, Sm, and Pg for 5 days shown in Figure 11.

The dental and oral disease such as periodontitis was initiated with the colonies of aerobic Gram-positive bacteria, such as streptococci, lactobacilli, and actinomycetes on the acquired pellicle formed at the surface of the teeth.^[16,17] After 2–4 days, several colony of Gram-negative bacteria, such as Pg, *Actinobacillus prevotella*, and the other Gram-negative bacteria would grow on that particular area. On the next step, the dominant pathogenic bacteria on the subgingival plaque, such as Pg, *Treponema denticola*, *Tanerella forsythensis*, Aa, *F nucleatum*, and *Eikenella corodens*, would grow on that plaque.^[18,19] This periodontal disease is an inflammation reaction as a body blockade of bacterial invasion.

Figures 9 and 10 show that TGS 826 and TGS 2602 gas sensors had a good response toward the gas produced by the bacterial biofilm that causes dental and oral disease. The measured voltage (volt) of the sensor was proportional to the concentration (ppm) of the absorbed gas based on the calibration of the sensor using the ammonia shown in Figure 12. Based on the previous study for tempeh odor identification along the fermentation process,^[20] six of eight sensors used showed a good response, which were TGS

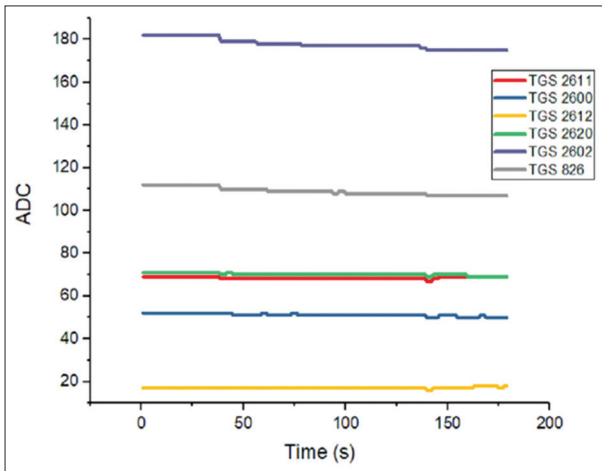

Figure 4: The sensor stability test output

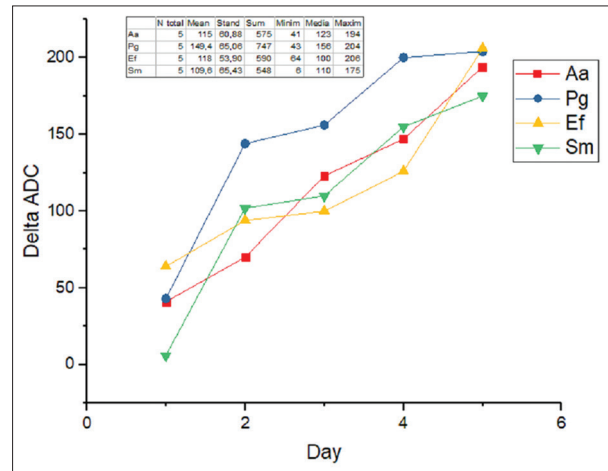

Figure 5: The response of TGS 2600 gas sensor

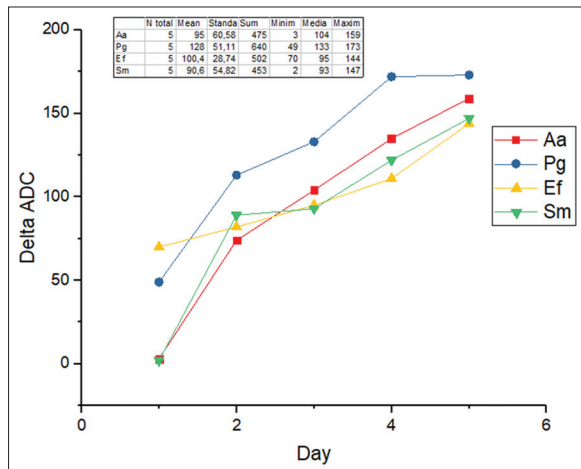

Figure 6: The response of TGS 2611 gas sensor

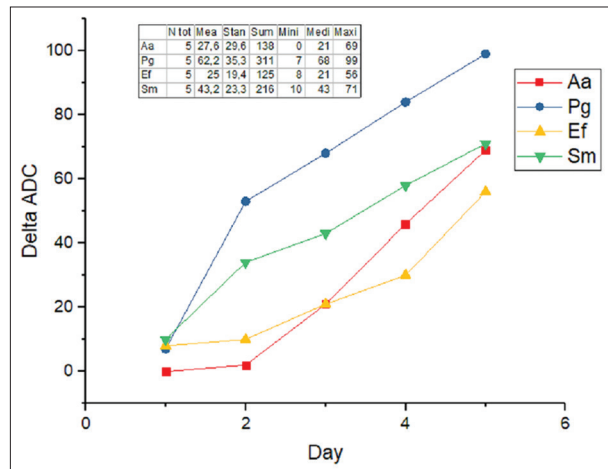

Figure 7: The response of TGS 2612 gas sensor

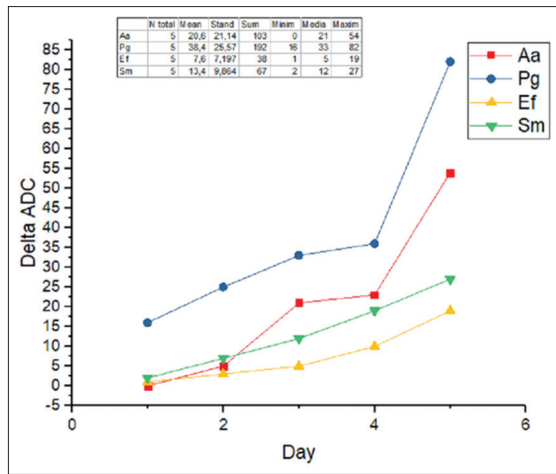

Figure 8: The response of TGS 2620 gas sensor

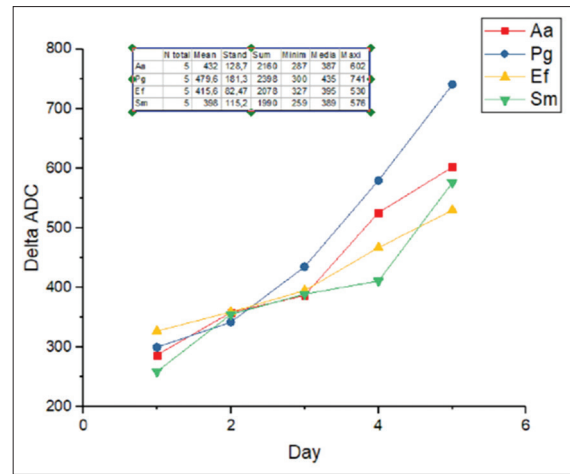

Figure 9: The response of TGS 2602 gas sensor

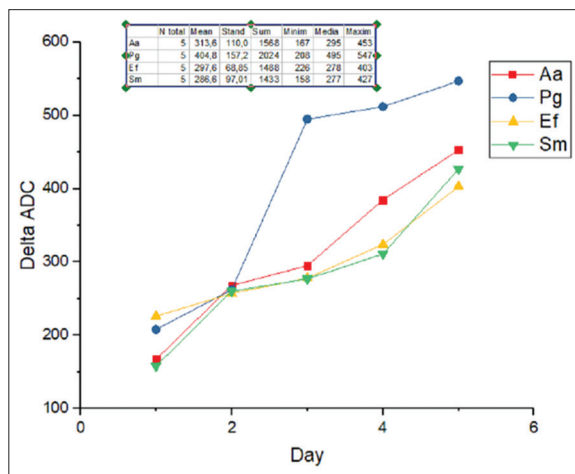

Figure 10: The response of TGS 826 gas sensor

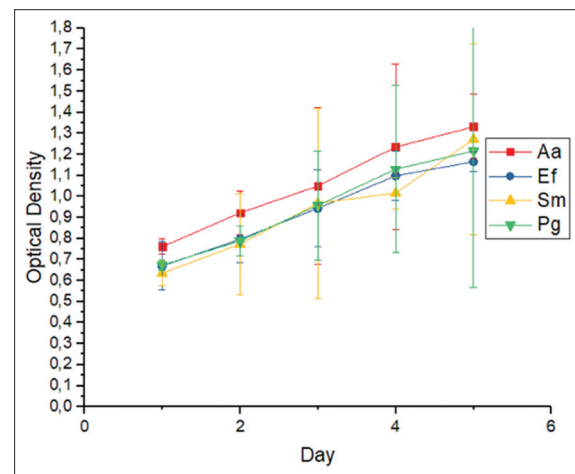

Figure 11: Optical density of Aa, Ef, Sm, and Pg for 5 days

813, TGS 822, TGS 2600, TGS 826, TGS 2620, and TGS 2602 gas sensors. These sensors could detect gases related to the ones produced by the bacterial biofilm, so that they could become a candidate for an early detection of dental and oral disease. For future study, the concentration of the gas should be considered because it shows the level of the amount of bacterial and is proportional to the severity of the disease. The voltage output of the sensor was between 0 V and 5 V with current below 500 mA. These data were converted to digital data using ADC from microcontroller with a resolution of 10 bit. The lowest value of ADC was 0 and its highest point was 1023. The delta ADC was obtained from the measurement of the minimum and maximum value of the ADC. The TGS sensor output voltage ranged from 0 to 800 or 0–3.9 V. The data storing was performed every minute for 50 min with data transfer rate of 9600 bps.

Biofilm is bacterial cell community that was attached to each other. It could produce polymeric matrices and attach to biological surfaces or another substance. One of the examples of biofilm which attaches to the dental

surface is dental plaque. The dental plaque is a form of biofilm, which leads to dental damage.^[21] The formation of plaque started with the colonization of Sm on the dental surface.^[22] This bacterium has a virulence factor that makes it to colonize, form biofilm, and produce acid to damage the teeth (hydroxyapatite calcium). It could also grow and do metabolism in the acid environment.^[23] Fifty percent of *Streptococcus* species was found on the human mouth cavity. Figure 11 shows that the number of bacterial colony in the biofilm was correlated to the time of biofilm formation. The longer the time of biofilm formation, the more bacterial colony formed. It was shown by the bacterial density. The result in Figure 11 showed that the bacterial biofilm increased each day.

The increase on bacterial density in the biofilm raised the odor excreted from the biofilm. This odor represented the mouth odor (halitosis) when the teeth were damaged. The main cause of halitosis is volatile sulfur compounds, such as hydrogen sulfide (H₂S), methyl mercaptan (CH₃SH), and dimethyl sulfide (CH₃SCH₃). It is originated from anaerobe Gram-negative bacterial activity in the supragingiva

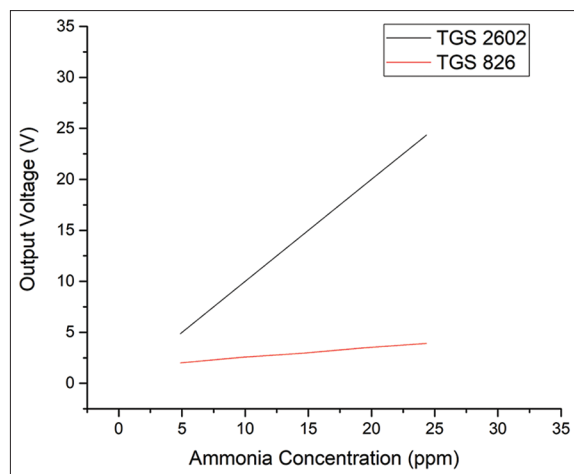

Figure 12: The proportional correlation between output voltage and ammonia concentration of TGS 2602 and TGS 826

region.^[24] The bacterial colony could increase due to bad oral hygiene, dental plaque, caries, gingivitis, stomatitis, periodontitis, tongue coating, xerostomia, oral carcinoma, and hormone.^[24,25]

The aromatic compounds are produced naturally by the plants. On the other hand, several bacteria also produce volatile aromatic compounds with strong odor. They are assumed obtained from aromatic amino acid degradation, such as L-phenylalanine or L-tyrosine. These compounds are produced by shikimate track.^[26]

The presence of acid production by the bacterial plaque caused mineral erosion on the dental caries. The plaque cariogenicity was related to the population level of acid-tolerant organisms, such as *Sm*. However, the biofilm properties on the dental plaque may cause the life of several microorganisms, including less acid-tolerant organism. Some of them could produce ammonia originating from arginine or urea to counteract the acidity. This ammonia is the main cause of halitosis or unpleasant odor of oral cavity.^[26,27]

Conclusion

Gas array sensor system with six gas sensors, which were TGS 826, TGS 2602, TGS 2600, TGS 2611, TGS 2612, and TGS 2620, has been designed for an early detection of dental and oral disease based on the odor produced by the bacterial biofilm casing dental and oral disease, such as *Aa*, *Pg*, *Sm*, and *Ef*. TGS 826 and TGS 2602 gas sensors had the best response shown by the delta ADC value. Thus, TGS 826 and TGS 2602 gas sensors could be used as a candidate for that purpose.

Financial support and sponsorship

None.

Conflicts of interest

There are no conflicts of interest.

References

- Jati HA, Lelono D. Deteksi dan monitoring polusi udara berbasis array sensor gas. *Indones J Electron Instrum Syst* 2013;3:147-56.
- Konduru T, Rains GC, Li C. Detecting sour skin infected onions using a customized gas sensor array. *J Food Eng* 2015;160:19-27.
- Triyana K, Tauhid SM, Aji P, Hidayat SN, Rohman A. Development of electronic nose with low-cost dynamic headspace for classifying vegetable oils and animal fats. *Appl Mechanics Mater* 2015;771:50-4.
- Imbronito AV, Okuda OS, de Freitas NM, Lotufo RF, Nunes FD. Detection of herpes viruses and periodontal pathogens in subgingival plaque of patients with chronic periodontitis, generalized aggressive periodontitis, or gingivitis. *J Periodontol* 2008;79:2313-21.
- Schnabel RM, Boumans ML, Smolinska A, Stobberingh EE, Kaufmann R, Roekaerts PM, *et al.* Electronic nose analysis of exhaled breath to diagnose ventilator-associated pneumonia. *Respir Med* 2015;109:1454-9.
- Hajishengallis G. Periodontitis: From microbial immune subversion to systemic inflammation. *Nat Rev Immunol* 2015;15:30-44.
- Longo DL, Fauci AS, Kasper DL, Hauser SL, Jameson JL, Loscalzo J. *Harrison's Principles of Internal Medicine*. Alabama: McGraw Hill Professional; 2012. p. 2.
- Carranza F, Newman M, Takei H. *Carranza's Clinical Periodontology*. 10th ed. Philadelphia: W.B. Saunders Company; 2006. p. 26-7.
- Nani BD, Lima PO, Marcondes FK, Groppo FC, Rolim GS, Moraes AB, *et al.* Changes in salivary microbiota increase volatile sulfur compounds production in healthy male subjects with academic-related chronic stress. *PLoS One* 2017;12:e0173686.
- Ju Y, Zhang W, Pei Y, Yang G. H(2)S signaling in redox regulation of cellular functions. *Can J Physiol Pharmacol* 2013;91:8-14.
- Persson S, Edlund MB, Claesson R, Carlsson J. The formation of hydrogen sulfide and methyl mercaptan by oral bacteria. *Oral Microbiol Immunol* 1990;5:195-201.
- Persson S. Hydrogen sulfide and methyl mercaptan in periodontal pockets. *Oral Microbiol Immunol* 1992;7:378-9.
- Biju T, Shabeer MM, Amitha R, Rajendra BP, Suchetha K. Comparative evaluation of serum superoxide dismutase and glutathione levels in periodontally diseased patients: An interventional study. *Indian J Dent Res* 2014;25:613-6.
- Peng Q, Tian R, Chen F, Li B, Gao H. Discrimination of producing area of Chinese Tongshan kaoliang spirit using gas array sensor system sensing characteristics combined with the chemometrics methods. *Food Chem* 2015;178:301-5.
- Wilson AD. Advances in electronic-nose technologies for the detection of volatile biomarker metabolites in the human breath. *Metabolites* 2015;5:140-63.
- Paulino TP, Magalhães PP, Thedei G Jr., Tedesco AC, Ciancaglini P. Use of visible light-based photodynamic therapy to bacterial photoinactivation. *Biochem Mol Biol Educ* 2005;33:46-9.
- Paulino TP, Ribeiro KF, Thedei G Jr., Tedesco AC, Ciancaglini P. Use of hand held photopolymerizer to photoinactivate *Streptococcus mutans*. *Arch Oral Biol* 2005;50:353-9.
- Bansal S, Rastogi S, Bajpai M. Mechanical, chemical and herbal aspects of periodontitis: A review. *Int J Pharm Sci Res* 2012;3:1260-1.

19. Mysak J, Podzimek S, Sommerova P, Lyuya-Mi Y, Bartova J, Janatova T, *et al.* *Porphyromonas gingivalis*: Major periodontopathic pathogen overview. *J Immunol Res* 2014;2014:476068.
20. Hidayat SH, Nuringtyas TR, Triyana K. Electronic Nose Coupled with Chemometrics for Monitoring of Tempeh Fermentation Process. 2018 4th International Conference on Science and Technology (ICST); 2018.
21. Aparna BD Pt., Yadav S. Biofilms: Microbes and disease. *Braz J Infect Dis* 2008;12:526-30.
22. Lemos JA, Quivey RG Jr., Koo H, Abranches J. *Streptococcus mutans*: A new gram-positive paradigm? *Microbiology* 2013;159:436-45.
23. Avilés-Reyes A, Miller JH, Simpson-Haidaris PJ, Lemos JA, Abranches J. Cnm is a major virulence factor of invasive *Streptococcus mutans* and part of a conserved three-gene locus. *Mol Oral Microbiol* 2014;29:11-23.
24. Kawamoto A, Sugano N, Motohashi M, Matsumoto S, Ito K. Relationship between oral malodor and the menstrual cycle. *J Periodontal Res* 2010;45:681-7.
25. Almas K, Al-Hawish A, Al-Khamis W. Oral hygiene practices, smoking habit, and self-perceived oral malodor among dental students. *J Contemp Dent Pract* 2003;4:77-90.
26. Schulz S, Dickschat JS. Bacterial volatiles: The smell of small organisms. *Nat Prod Rep* 2007;24:814-42.
27. Marquis RE. Oxygen metabolism, oxidative stress and acid-base physiology of dental plaque biofilms. *J Ind Microbiol* 1995;15:198-207.

BIOGRAPHIES



Suryani Dyah Astuti is a lecturer in Department of Physics, Faculty of Science and Technology, Universitas Airlangga, Indonesia. She got her bachelor, master, and doctoral degree from Universitas Gadjah Mada majoring Physics, Bandung Institute of Technology majoring in Physics, and Universitas

Airlangga in Mathematics and Natural Science. All of them are in Indonesia. Her research field are antimicrobial Photodynamic Therapy (aPDT) and medical physics.

Email: suryanidyah@fst.unair.ac.id



Yanuar Mukhammad is a master student in department of biomedical engineering, postgraduate school, Universitas Airlangga, Indonesia. His research field is biomedical sensors.

Email: yanuarm@gmail.com



Sirlus Andreanto Jasman Duli is a master student in department of biomedical engineering, postgraduate school, Universitas Airlangga, Indonesia. His research field is biomedical sensors.

Email: sirlusjasman@gmail.com



Alfian Pramudita Putra is a lecturer in Bachelor of Biomedical Engineering, Department of Physics, Faculty of Science and Technology, Universitas Airlangga, Indonesia. He got his bachelor, and master degree from Universitas Airlangga, Indonesia and University of Groningen, Netherlands, respectively. His research

field is biomedical product development.

Email: alfian.pramudita@fst.unair.ac.id



Ernie Maduratna Setiawatie is a lecturer in Faculty of Dentistry, Universitas Airlangga, Indonesia. She got her bachelor, master, and doctoral degree from Universitas Airlangga in in Dentistry. All of them are in Indonesia. Her research field are Periodontics.

Email: ernie-m-s@fkg.unair.ac.id



Kuwat Triyana is a lecturer from Universitas Gadjah Mada. He got his bachelor, master, and doctoral degree from Universitas Gadjah Mada, Bandung Institute of Technology, Indonesia and Kyushu University, Japan, respectively. His research field is material science.

Email: triyana@ugm.ac.id
