

Markerless Respiratory Tumor Motion Prediction Using an Adaptive Neuro-fuzzy Approach

Abstract

Background: Accurate delivery of the prescribed dose to moving lung tumors is a key challenge in radiation therapy. Tumor tracking involves real-time specifying the target and correcting the geometry to compensate for the respiratory motion, that's why tracking the tumor requires caution. This study aims to develop a markerless lung tumor tracking method with a high accuracy. **Methods:** In this study, four-dimensional computed tomography (4D-CT) images of 10 patients were used, and all the slices which contained the tumor were contoured for all patients. The first four phases of 4D-CT images which contained tumors were selected as input of the software, and the next six phases were considered as the output. A hybrid intelligent method, adaptive neuro-fuzzy inference system (ANFIS), was used to evaluate motion of lung tumor. The root mean square error (RMSE) was used to investigate the accuracy of ANFIS performance for tumor motion prediction. **Results:** For predicting the positions of contoured tumors, the averages of RMSE for each patient were calculated for all the patients. The results showed that the RMSE did not have a major variation. **Conclusions:** The data in the 4D-CT images were used for motion tracking instead of using markers that lead to more information of tumor motion with respect to methods based on marker location.

Keywords: Adaptive neuro-fuzzy inference system model, adaptive prediction model, external radiotherapy, tumor tracking

Introduction

Lung cancer is one of the most important causes of cancer deaths in the world. This cancer is the most common cause of death in men and the second leading cause of death in women, after breast cancer.^[1] The main purpose in external radiotherapy is delivering three-dimensional (3D) uniform dose into tumor volume and minimizing the dose to the healthy tissues. Respiratory motion causes significant motion of thoracic and abdominal organs and affects the targeting of external beam to lung tumors and so introduces uncertainties in radiation therapy. Therefore, it is a source of inaccuracy in image acquisition and lung tumor treatment. For some cases, the respiration tumor motion may be at the order of >2–3 cm. Thus, motion management techniques play an important role in protecting healthy tissues and damage to the moving tumor.

To adapt a proper beam delivery for breathing or lung tumor motion, two techniques have been developed: Gating and tracking. The

goal in the gating approach is to select the time interval, in which the lung tumor moves into a predefined small gating window.^[2-5] In the tracking approach, the beam follows the moving tumor.^[6-9] The basic requirement for these techniques is the ability to predict the tumor motion versus time. Real-time tumor-tracking radiotherapy was developed in 1999 to amplify the precision of irradiation of moving lung tumors.^[10]

Several studies have been conducted to move the beam according to tumor motion in the lung.^[11-16] These studies used additional monitoring hardware such as optical tracking and fluoroscopy for real-time tumor tracking.^[17-21] Although direct tumor tracking techniques without external markers and implanting fiducial markers are desired as more sophisticated method, usually, external markers, located on the chest of the patient, are used to predict the lung tumor motion. Therefore, this study was conducted to predict lung tumor motion without any markers using the adaptive neuro-fuzzy inference system (ANFIS) methodology.^[22]

How to cite this article: Rostampour N, Jabbari K, Esmaeili M, Mohammadi M, Nabavi S. Markerless respiratory tumor motion prediction using an adaptive neuro-fuzzy approach. *J Med Sign Sens* 2018;8:25-30.

Nima Rostampour^{1,2},
Keyvan Jabbari¹,
Mahdad Esmaeili³,
Mohammad
Mohammadi⁴,
Shahabedin Nabavi⁵

¹Department of Medical Physics, Isfahan University of Medical Sciences, Isfahan, Iran, Medical Image and Signal Processing Research Center, Isfahan University of Medical Sciences, Isfahan, Iran, ²Department of Medical Physics, School of Medicine, Kermanshah University of Medical Sciences, Kermanshah, Iran, ³Department of Medical Engineering, Tabriz University of Medical Sciences, Tabriz, Iran, ⁴Department of Medical Physics, Royal Adelaide Hospital, Adelaide, South Australia, Australia, ⁵Department of Computer Sciences, Faculty of Computer Science and Engineering, Shahid Beheshti University, Tehran, Iran

Address for correspondence:
Dr. Keyvan Jabbari,
Department of Medical Physics,
Isfahan University of Medical
Sciences, Isfahan, Iran, Medical
Image and Signal Processing
Research Center, Isfahan
University of Medical Sciences,
Isfahan, Iran.
E-mail: jabbari@med.mui.ac.ir

Website: www.jmss.mui.ac.ir

This is an open access article distributed under the terms of the Creative Commons Attribution-NonCommercial-ShareAlike 3.0 License, which allows others to remix, tweak, and build upon the work non-commercially, as long as the author is credited and the new creations are licensed under the identical terms.

For reprints contact: reprints@medknow.com

Esmaili Torshabi *et al.* analyzed substantial effects of two different data clustering approaches on the fuzzy modeler performance. The performance of adaptive and multiple fuzzy logic models was tested in 20 patients treated with CyberKnife. The final results showed that activating adequate model selection of our fuzzy-based modeler can significantly reduce tumor tracking errors.^[23] In other study, Choi *et al.* showed that clinically applicable results from the viewpoint of training and predicting time, which may be effective for predicting patient breathing motion and thus enhancing the efficacy of radiation therapy.^[24] Rottmann and Berbeco investigated the feasibility of training a respiratory motion prediction model with an external surrogate signal to avoid exposure of patients from additional dose due to imaging during this procedure. Their linear prediction model could reduce latency-induced tracking errors by an average of about 50% in real-time image-guided radiotherapy systems with the system.^[25] Yun *et al.* developed a new ANN-based lung-tumor motion predictor for MRI-based intrafractional tumor tracking.

In comparison of the previous studies, in this work, a markerless method was used for prediction of the tumor position based on four-dimensional computed tomography (4D-CT) images of the patients. The organization of this paper is as follows: the next section discusses the ANFIS system algorithm, in the section of prediction of tumor position, an implementation of the algorithm is shown, and the results are presented after that. Finally, we conclude and give some perspectives for future work.

Materials and Methods

Adaptive Neuro-fuzzy inference system

Adaptive network is a feedforward dynamical neural network with several layers [Figure 1]. These networks in the learning process often use supervised learning algorithm. In addition, in the architecture of adaptive network, there are a number of adaptive nodes that have been interconnected straightly without any weight value between them. The functions and roles of each node in this network are different, and the output relies on the available input signals and parameters that are existed in the node. Parameters in the node are affected by learning rule that

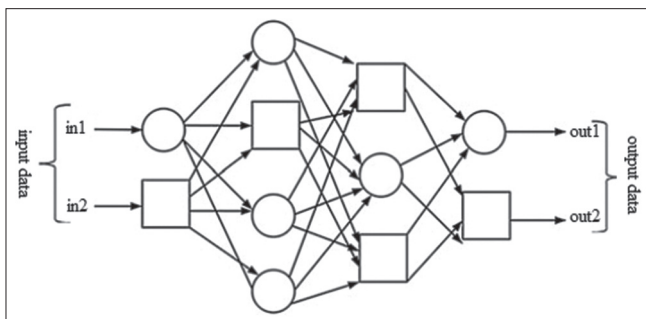

Figure 1: Architecture of adaptive network

was used, and it can decrease the incidence of errors at the output of the adaptive network.^[22]

The gradient descent or back propagation algorithm and the chain rule are commonly used in learning the basic adaptive network. The slow convergence rate and getting stuck easily in local minima are major problems on backpropagation algorithm. Therefore, an alternative learning algorithm, namely, hybrid learning algorithm have been introduced^[22] which has the effective strength to speed up the convergence and prevent the occurrence of trapped in local minima.

ANFIS is an adaptive network method which uses the neural network with fuzzy inference system to assistant the inputs to the tumor motion as output.^[26-29] An artificial neural network (ANN) is a method based on function approximation, and this model is based on the biological processing of brain neurons.^[30] In this study, ANFIS technique was used to combine the advantages of fuzzy systems with numeric power in neural adaptive network systems. With ANFIS both neural network and fuzzy logic are able to share their ability to predict lung tumor motion.

The first and the fourth layers in the ANFIS architecture have parameters that can be modified over time. In the first layer, it comprises a nonlinear of the premises parameter while the fourth layer contains linear consequent parameters. A hybrid algorithm proposed by Jang^[22] is used to update both of these parameters. The forward path and backward path are two parts of a hybrid learning algorithm. The parameters of the premises in the first layer of the forward path must be in a steady state. The consequent parameter in the fourth layer was repaired by a recursive least square estimator method. The convergence rate in the hybrid learning process is accelerated with the use of RSLE method. Input data are returned to the adaptive network input after the consequent parameters are obtained, and the obtained output will be compared with the true output. The occurred error within the comparison between the outputs produced with the true output is propagated back to the first layer. Simultaneously, learning methods of gradient descent or backpropagation is used to update the parameter premises in the first layer.

As an example in ANFIS structure, assuming that x and y are input variables for single-output fuzzy inference system, the output variable is calculated with applying of fuzzy rules to a fuzzy set of input variables. The rule set in this method contains two fuzzy if-then rules for the first-order Sugeno fuzzy model:^[31,32]

$$\text{Rule 1: If } x \text{ is } A_1 \text{ and } y \text{ is } B_1 \text{ then, } f_1 = p_1x + q_1y + r_1 \quad (1)$$

$$\text{Rule 2: If } x \text{ is } A_2 \text{ and } y \text{ is } B_2 \text{ then, } f_2 = p_2x + q_2y + r_2 \quad (2)$$

Where p_i , q_i , and r_i ($i = 1$ or 2) are linear parameters and A_i , B_i are linguistic labels. These parameters are characterized by proper membership functions (MF).^[22] With MF curve one can defines the number of points in the input space that

is mapped to a membership P value between 0 and 1. MFs are the building blocks of fuzzy set theory, and they may have different shapes such as trapezoidal, triangular, and Gaussian. The Gaussian and bell-shape MFs are usually used to specify fuzzy sets.

Prediction of tumor position

To develop and evaluate the proposed algorithms, 4D-CT images for 10 lung cancer patients were acquired with multislice Brilliance CT Big Bore OncologyTM[33]. The data information related to breathing correlated was obtained using the Pneumo Chest bellows. Each data set contained ten 3D-CT phases, representing a breathing cycle.

All the slices which contained tumor were selected for 10 patients, and the tumor margins were delineated in the selected slices. A breathing cycle for each patient contained 10 phases. In all slices, the tumor was contoured by a radiation oncologist. For training of algorithm, the contoured tumors in each slice of four successive phases in 4D-CT images were considered as an input. The algorithm was used to predict the next phase as the output. For example, the phases of three to six were used for training the input data, and the seventh phase was predicted. Tumor motion in three directions (x , y , and z) was considered for prediction of the motion. For simplicity, the centers of contoured tumors in three directions were selected for tracking. The center of the tumor was obtained by taking an average over the position of tumor voxels, and the centers of tumor were tracked slice by slice. The training was performed for the first six patients, and other four patients were used for the evaluation of algorithm in the prediction of tumor motion. All algorithms in this work were applied on the CT images using MATLAB software.

The most widely used MF in Fuzzy logic is the bell MF. The generalized Bell MF block use an MF with Simulink[®] toll box of MATLAB using a generalized bell-shaped curve. The generalized bell-shaped curve can be calculated by:[32,34]

$$\text{Bell}(x; a, b, c) = \frac{1}{1 + \left| \frac{x-c}{a} \right|^{2b}} \quad (3)$$

Where the b is positive, the parameter c locates the center of the curve, and a shows width of the curve [Figure 2].

The ANFIS method in this work was a multilayer neuro-fuzzy method, and the related fuzzy inference system was based on Sugeno type.[35] Sugeno-type inference is a more compact and computationally efficient, and it also uses adaptive techniques for fuzzy models. These adaptive techniques can also be used to customize MFs to model the data accurately by fuzzy system. Figure 3 illustrates the topology of Sugeno type which has a total of five layers:

- Layer 1: Each node in this layer adjusts to a function parameter. Degree of membership value is the output

from each node that is given by the input of the MFs. The parameters in this layer are commonly considered as the premise parameters

- Layer 2: Each node in this layer is constant or nonadaptive, and the circle node is tagged as π . The output node is the result of multiplying of signal coming into the node and conveyed to the next node. Each node in this layer represents the firing strength for each rule. In the second layer, the T-norm operator with general performance, such as the AND, is applied to obtain the output

$$O_{2i} = w_i = \mu_{Ai}(x) * \mu_{Bi}(y), \quad i = 1, 2 \quad (4)$$

- Layer 3: Each node in this layer is constant or nonadaptive, and the circle node is tagged as N . Every node is a calculation of the ratio between the i^{th} firing strength of a rule and the sum of all rules' firing strengths.

$$O_{3i} = \bar{w}_i = \frac{w_i}{\sum_i w_i} \quad (5)$$

- Layer 4: Each node in this layer is an adaptive node to an output. The parameters in this layer are defined as consequent parameters with a node function defined

$$O_{4i} = \bar{w}_i f_i = \bar{w}_i (p_i x + q_i y + r_i) \quad (6)$$

- Layer 5: The single node in this layer is a fixed or nonadaptive node that the summation of all incoming signals from the previous node produces the total output. In this layer, a circle node is tagged as Σ .

$$O_{5i} = \sum_i \bar{w}_i f_i = \frac{\sum_i w_i f_i}{\sum_i w_i} \quad (7)$$

In this structure, the training and predicted values were considered as input and output, respectively. In the hidden layers, there were also several nodes functioning as MFs. The learning algorithm used in ANFIS was one of the hybrid algorithms, which consisted of the least-squares and gradient descent method. The measured error to train the mentioned ANFIS was given by:[32]

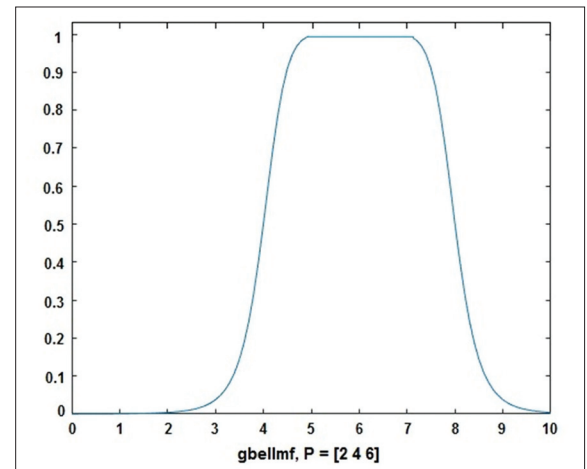

Figure 2: An illustration of the generalized bell membership function

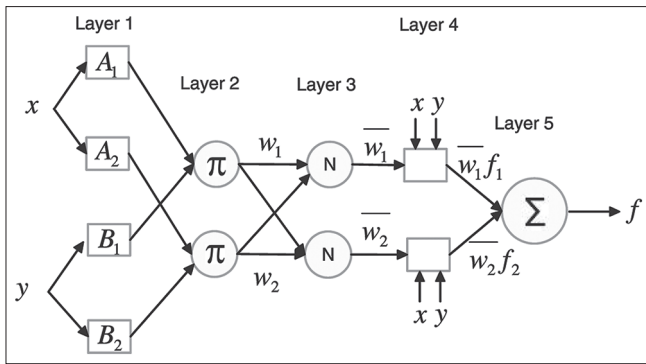

Figure 3: A Sugeno-type model with adaptive neuro-fuzzy inference system architecture^[31]

$$\text{Root mean square error (RMSE)} = \sqrt{\frac{1}{N} \sum_{i=1}^N (A_i - P_i)^2} \quad (8)$$

In which N is the number of predicted samples, A_i and P_i are i^{th} desired and number of predicted output, respectively. The RMSE was computed for each patient, and the average RMSE was used for prediction of lung tumor motion.

Simulations of this work were performed with a 2.53 GHz Intel core i5 processor. The in-house ANFIS algorithm was trained using the Matlab R2014a.

Results

To investigate the accuracy of ANFIS performance for tumor motion prediction, a statistical parameter was used as the RMSE. RMSE is equal to the difference between corresponding observed values and predicted values. The differences were squared and then averaged over the samples; and then, the square root of the average value was taken. The average of RMSE of each patient was calculated for tracking the positions of contoured tumors. The type and number of parameters for training ANFIS are illustrated in Table 1. Table 2 illustrates the value of mean and standard deviation calculated from RMSE of patients in three directions.

As the tumor motion was considered in three directions (x, y, and z), Figures 4-6 illustrate the training data and ANFIS output in the directions of x, y, and z, respectively.

Discussion

According to the results, using ANFIS with a hybrid intelligent method gives acceptable accuracies for predicting of lung tumor motion. Some of the benefits of using ANFIS for prediction are: (a) combination of two technologies of fuzzy systems and neural networks; (b) in fuzzy techniques, numerical and linguistic knowledge can be combined into a fuzzy rule base; (c) using learning methods, fuzzy MFs can be tuned with high efficiency; and (d) compared to neural networks, in this technique, the requirements for architecture are simpler and fewer. In this

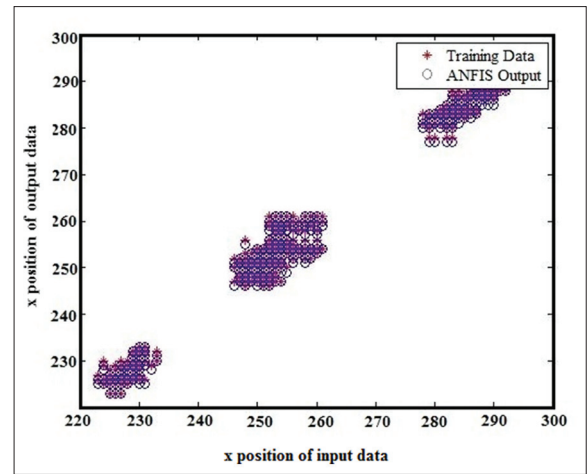

Figure 4: Adaptive neuro-fuzzy inference system and training data output in the direction of x

Table 1: Various parameters which are used for training of adaptive neuro-fuzzy inference system

ANFIS parameters	Value
MF type	Bell function
Number of MFs	5
Output MF	Linear
Number of nodes	1297
Number of linear parameters	3125
Number of nonlinear parameters	60
Total number of parameters	3185
Number of training data pairs	420
Number of checking data pairs	420
Number of fuzzy rules	625

ANFIS – Adaptive neuro-fuzzy inference system; MFs – Membership functions

Table 2: The results of root mean square error per patient which calculated by adaptive neuro-fuzzy inference system

Statistical parameters	Direction	Average RMSE
Mean±SD	X	0.1437±0.005
	Y	0.1860±0.008
	Z	0.3612±0.009

RMSE – Root mean square error; SD – Standard deviation

work, Bell MF was used because this method is specified by three parameters and has one more parameter compared to the Gaussian MF, so it can use a nonfuzzy set as long as the free parameter is tuned. Because of their concise notation and smoothness, bell MF is a popular method for specifying fuzzy sets. It has the advantage of being nonzero and smooth at all points. The followings are the advantages of using Sugeno:^[36] (a) it is computationally efficient, (b) it is connected to the linear techniques, (c) it works well with adaptive techniques and optimization, (d) it has acceptable continuity for the output surface, and (e) this method is proper for mathematical analysis.

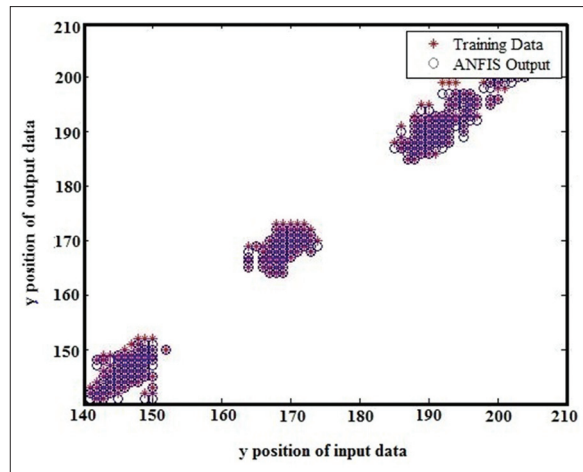

Figure 5: Adaptive neuro-fuzzy inference system and training data output in the direction of y

The training was performed for first six patients, and the next four patients were used for test to evaluate the lung tumor tracking accuracies. It was observed in the results that the RMSE did not have a large variation. Based on the literature, many of the most cited articles on lung tumor motion estimation using 4D-CT datasets have used the 4D-CT data from 5 to 12 patients.^[37-43]

In this study, instead of using markers, the data in the 4D-CT images were used for motion tracking. This results to more information of tumor motion in comparison with methods based on marker location. In the systems based on marker detection, the treatment is less convenient because IR system is used, the patient holds the breath, and more labor work is needed. In the use of 4D-CT, it is possible to track the tumor in off-line bases.

Since the amount of raw input data was relatively low (the data for the various location of the tumor in the lung), and the data were not normalized, there was some fluctuation in the results. With normalization of the input in the future study; the output fluctuation can be reduced.

The robustness of proposed method in this study can be evaluated for large dataset, and the number of MFs can be increased if we have no limitation in the computing system. Better accuracies can be expected if there are no limitations. The nonlinear nature of breathing will also degrade the quality of prediction, and by increasing the training data, we can overcome the nonstationary breathing patterns that were accrued in the images.

The authors are intended to apply the method in experimental tools in the future. In the future work, it is suggested that with the investigation of tumor model, the variation of the shape can be predicted during the breathing cycle.

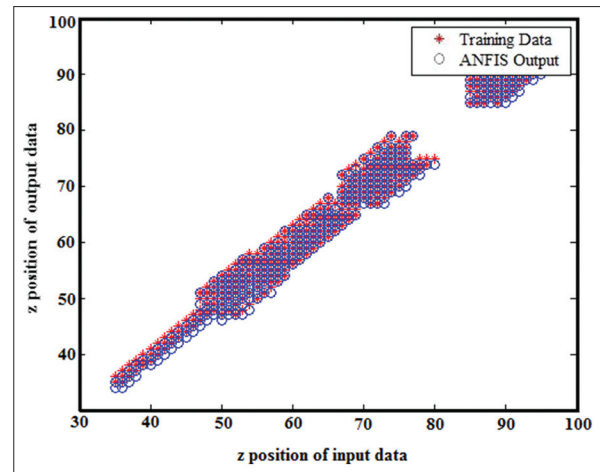

Figure 6: Adaptive neuro-fuzzy inference system and training data output in the direction of z

Acknowledgment

The authors are grateful to the Vice Chancellor for Research and Technology, Isfahan University of Medical Sciences grant (2015) for supporting this project (No. 394530).

Financial support and sponsorship

This study was financially supported by Isfahan University of Medical Sciences.

Conflicts of interest

There are no conflicts of interest.

References

1. Parkin DM, Bray F, Ferlay J, Pisani P. Global cancer statistics, 2002. *CA Cancer J Clin* 2005;55:74-108.
2. Kubo HD, Len PM, Minohara S, Mostafavi H. Breathing-synchronized radiotherapy program at the university of california davis cancer center. *Med Phys* 2000;27:346-53.
3. Ohara K, Okumura T, Akisada M, Inada T, Mori T, Yokota H, *et al.* Irradiation synchronized with respiration gate. *Int J Radiat Oncol Biol Phys* 1989;17:853-7.
4. Seppenwoolde Y, Shirato H, Kitamura K, Shimizu S, van Herk M, Lebesque JV, *et al.* Precise and real-time measurement of 3D tumor motion in lung due to breathing and heartbeat, measured during radiotherapy. *Int J Radiat Oncol Biol Phys* 2002;53:822-34.
5. Shirato H, Shimizu S, Kunieda T, Kitamura K, van Herk M, Kagei K, *et al.* Physical aspects of a real-time tumor-tracking system for gated radiotherapy. *Int J Radiat Oncol Biol Phys* 2000;48:1187-95.
6. Keall PJ, Kini VR, Vedam SS, Mohan R. Motion adaptive x-ray therapy: A feasibility study. *Phys Med Biol* 2001;46:1-0.
7. Murphy MJ. Tracking moving organs in real time. *Semin Radiat Oncol* 2004;14:91-100.
8. Neicu T, Shirato H, Seppenwoolde Y, Jiang SB. Synchronized moving aperture radiation therapy (SMART): Average tumour trajectory for lung patients. *Phys Med Biol* 2003;48:587-98.
9. Schweikard A, Shiomi H, Adler J. Respiration tracking in radiosurgery. *Med Phys* 2004;31:2738-41.
10. Shirato H, Shimizu S, Shimizu T, Nishioka T, Miyasaka K.

- Real-time tumour-tracking radiotherapy. *Lancet* 1999;353:1331-2.
11. Murphy MJ, Jalden J, Isaksson M. Adaptive Filtering to Predict Lung Tumor Breathing motion During Image-Guided Radiation Therapy. In Proceedings of the 16th International Congress on Computer-Assisted Radiology and Surgery, Paris: 2002. p. 539-44.
 12. Sharp GC, Jiang SB, Shimizu S, Shirato H. Prediction of respiratory tumour motion for real-time image-guided radiotherapy. *Phys Med Biol* 2004;49:425-40.
 13. Vedam SS, Keall PJ, Docef A, Todor DA, Kini VR, Mohan R, *et al.* Predicting respiratory motion for four-dimensional radiotherapy. *Med Phys* 2004;31:2274-83.
 14. Isaksson M, Jalden J, Murphy MJ. On using an adaptive neural network to predict lung tumor motion during respiration for radiotherapy applications. *Med Phys* 2005;32:3801-9.
 15. Murphy MJ, Dieterich S. Comparative performance of linear and nonlinear neural networks to predict irregular breathing. *Phys Med Biol* 2006;51:5903-14.
 16. Qiu P, D'Souza WD, McAvoy TJ, Ray Liu KJ. Inferential modeling and predictive feedback control in real-time motion compensation using the treatment couch during radiotherapy. *Phys Med Biol* 2007;52:5831-54.
 17. Cerviño LI, Du J, Jiang SB. MRI-guided tumor tracking in lung cancer radiotherapy. *Phys Med Biol* 2011;56:3773-85.
 18. Hughes S, McClelland J, Tarte S, Lawrence D, Ahmad S, Hawkes D, *et al.* Assessment of two novel ventilatory surrogates for use in the delivery of gated/tracked radiotherapy for non-small cell lung cancer. *Radiother Oncol* 2009;91:336-41.
 19. Shah AP, Kupelian PA, Willoughby TR, Meeks SL. Expanding the use of real-time electromagnetic tracking in radiation oncology. *J Appl Clin Med Phys* 2011;12:3590.
 20. Shimizu S, Shirato H, Kitamura K, Ogura S, Akita-Dosaka H, Tateishi U, *et al.* Fluoroscopic real-time tumor-tracking radiation treatment (RTRT) can reduce internal margin (IM) and set-up margin (SM) of planning target volume (PTV) for lung tumors. *Int J Radiat Oncol Biol Phys* 2000;48:166-7.
 21. Zhong Y, Stephans K, Qi P, Yu N, Wong J, Xia P, *et al.* Assessing feasibility of real-time ultrasound monitoring in stereotactic body radiotherapy of liver tumors. *Technol Cancer Res Treat* 2013;12:243-50.
 22. Jang JS. ANFIS: Adaptive-network-based fuzzy inference system. *IEEE Trans Syst Man Cybern* 1993;23:665-85.
 23. Esmaili Torshabi A, Riboldi M, Imani Fooladi AA, Modarres Mosalla SM, Baroni G. An adaptive fuzzy prediction model for real time tumor tracking in radiotherapy via external surrogates. *J Appl Clin Med Phys* 2013;14:4008.
 24. Choi SW, Chang Y, Kim N, Park SH, Song SY, Kang SH. Performance enhancement of respiratory tumor motion prediction using adaptive support vector regression: Comparison with adaptive neural network method. *Int J Imaging Syst Technol* 2014;24:8-15.
 25. Rottmann J, Berbeco R. Using an external surrogate for predictor model training in real-time motion management of lung tumors. *Med Phys* 2014;41:121706.
 26. Zadeh LA. Fuzzy sets. *Inf Control* 1965;8:338-53.
 27. Zadeh LA. Outline of a new approach to the analysis of complex systems and decision processes. *IEEE Trans Syst Man Cybern* 1973;3:28-44.
 28. Zadeh LA. Fuzzy logic. *Computer* 1988;21:83-93.
 29. Zedeh L. Knowledge representation in fuzzy logic. *Knowledge and data engineering. IEEE Trans Syst Man Cybern* 1989;1:89-100.
 30. Bishop CM. *Neural Networks for Pattern Recognition*. New York, USA: Oxford University Press, Inc.; 1995.
 31. Kakar M, Nyström H, Aarup LR, Nøttrup TJ, Olsen DR. Respiratory motion prediction by using the adaptive neuro fuzzy inference system (ANFIS). *Phys Med Biol* 2005;50:4721-8.
 32. Loukas YL. Adaptive neuro-fuzzy inference system: An instant and architecture-free predictor for improved QSAR studies. *J Med Chem* 2001;44:2772-83.
 33. Vandemeulebroucke J, Rit S, Kybic J, Clarysse P, Sarrut D. Spatiotemporal motion estimation for respiratory-correlated imaging of the lungs. *Med Phys* 2011;38:166-78.
 34. Jang JS, Sun CT. Neuro-fuzzy modeling and control. *Proc IEEE* 1995;83:378-406.
 35. Takagi T, Sugeno M. Fuzzy identification of systems and its applications to modeling and control. *IEEE Trans Syst Man Cybern* 1985;15:116-32.
 36. Sivanandam SN, Sumathi S, Deepa SN. *Introduction to Fuzzy Logic Using MATLAB*. Springer-Verlag Berlin Heidelberg; 2007. p. 127.
 37. Admiraal MA, Schuring D, Hurkmans CW. Dose calculations accounting for breathing motion in stereotactic lung radiotherapy based on 4D-CT and the internal target volume. *Radiother Oncol* 2008;86:55-60.
 38. Boldea V, Sharp GC, Jiang SB, Sarrut D. 4D-CT lung motion estimation with deformable registration: Quantification of motion nonlinearity and hysteresis. *Med Phys* 2008;35:1008-18.
 39. Heinzerling JH, Anderson JF, Papiez L, Boike T, Chien S, Zhang G, *et al.* Four-dimensional computed tomography scan analysis of tumor and organ motion at varying levels of abdominal compression during stereotactic treatment of lung and liver. *Int J Radiat Oncol Biol Phys* 2008;70:1571-8.
 40. Purdie TG, Moseley DJ, Bissonnette JP, Sharpe MB, Franks K, Bezjak A, *et al.* Respiration correlated cone-beam computed tomography and 4DCT for evaluating target motion in stereotactic lung radiation therapy. *Acta Oncol* 2006;45:915-22.
 41. Underberg RW, Lagerwaard FJ, Slotman BJ, Cuijpers JP, Senan S. Use of maximum intensity projections (MIP) for target volume generation in 4DCT scans for lung cancer. *Int J Radiat Oncol Biol Phys* 2005;63:253-60.
 42. Weiss E, Wijesooriya K, Dill SV, Keall PJ. Tumor and normal tissue motion in the thorax during respiration: Analysis of volumetric and positional variations using 4D CT. *Int J Radiat Oncol Biol Phys* 2007;67:296-307.
 43. Werner R, Ehrhardt J, Schmidt R, Handels H. Patient-specific finite element modeling of respiratory lung motion using 4D CT image data. *Med Phys* 2009;36:1500-11.